



Catalog VFD-HV300 General Purpose Drive

(0.4kW~500kW)

About Hopewind

Shenzhen Hopewind Electric Co., Ltd. (Stock Code: SSE-603063) focuses on the research, manufacture, sales and service of renewable energy & electric drive products, with main products of MW level wind power VFD, Engineering VFD, Common VFD, PV VFD, APF active filter, SVG, Shore power and PCS. Through innovation in technology and service, Hopewind continuously creates value for customers, and has become one of the most competitive enterprises in renewable energy field. In the field of industrial drive, Hopewind independently developed HD2000 series low voltage engineering type VFD, HD8000 series medium voltage multi-level VFD and HV500 series high performance VFD base on powerful customized engineering wind power converter platform. In addition, Hopewind also have HV300 series common VFD, Oilfield dedicated HEC series VFD. The industrial drive products of Hopewind contain multiple power sections and different control modes, suitable for various industrial scenarios.

[Honors]



National Science and Technology Progress Award



Laboratory Qualification Approved by CNAS



National High-tech Enterprises

[Quality System]



ISO9001: 2015



ISO14001: 2015



ISO45001: 2018

Headquarter · Shenzhen

6 R&D and manufacturing bases: Shenzhen, Suzhou, Dongguan, Yancheng, Xi'an, Heyuan

30+ Global service bases: Deployed worldwide, and provides comprehensive services for global customers



General Technical Specifications

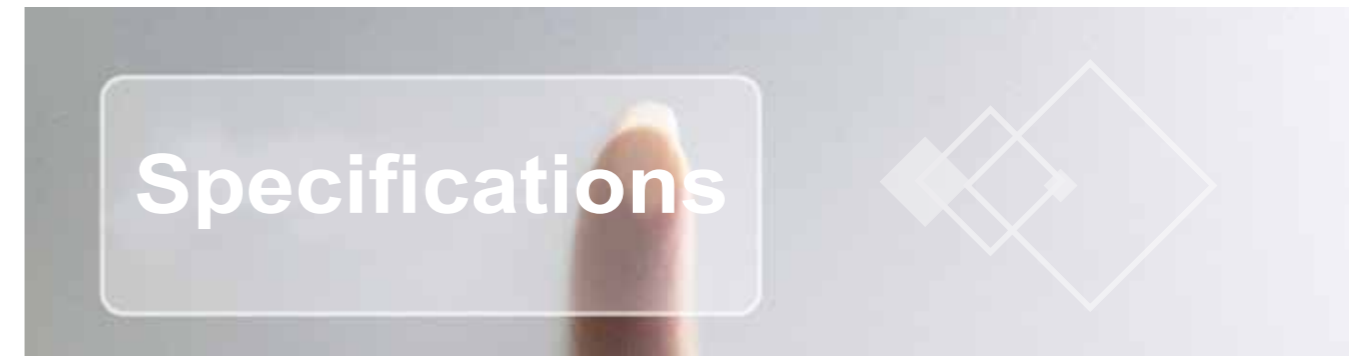

Input/Output Power	Input Voltage U_{in}	200V (-15%) ~ 240V (+10%) 1PH/3PH 380V (-15%) ~ 480V (+10%) 3PH 500V 500V (-15%) ~ 690V (+10%) 3PH
	Input Frequency	50Hz/60Hz±5%
	Maximum Supply Imbalance	≤3%
	Output Voltage	0V ~ U_{in}
	Output Frequency	0Hz ~ 300Hz
Main Control Performance	Power Range	0.4kW ~ 500kW
	Voltage Control	V/F, OLVC (Open Loop Vector Control)
	Adjust Speed	1:100 (OLVC), 1:50 (V/F)
	Start Torque	0.5Hz: 150% (OLVC), 1Hz: 150% (OLVC)
	Torque Accuracy	≤5% (OLVC)
	Torque Pulsation	≤2% (OLVC)
	Steady Operation Speed Accuracy	≤1% n_0 (Rated condition)
	Resolution	0.01Hz (Digit), 0.1%×Max. frequency (Analog)
	Torque Boost	0.1s ~ 3600min
	Torque Boost	0.1% ~ 30.0%
	Overload	E, G type: 150% rated output current, 1 minute P type: 110% rated output current, 1 minute
	V/F	4 types: V/F (user can program) and ramp (2.0 power, 1.7 power, 1.2 power)
	DC Braking	Injection frequency: 0.0% ~ 100.0% Max. frequency Injection current: 0.0% ~ 300.0% rated current Injection time: 0.00s ~ 60.00s
	Dynamic Brake	22kW and below models have built-in brake unit Brake rate: 0.0% ~ 100.0% Default dynamic brake DC voltage: 390V (220V voltage level products) 780V (380V voltage level products) 1125V (690V voltage level products)
	Jog	Jog frequency: 0.00Hz ~ maximum frequency Jog acceleration rate: 0.1s ~ 600.0s Jog interval time: 0.1s ~ 600.0s
Preset	16 preset speeds (decided by control terminals)	
AVR	Maintain the output voltage of motor V/F when the input power supply voltage changed	
Special Control Function	Built-in PID	Build close loop control system easily
	PMSM Soft-start Grid-tie Function	When drives the PMSM (permanent magnet synchronous motor) to the grid frequency, the switch will act to get the power supply from the grid without current impact, and the VFD will stop running
	Advanced Function Blocks	2 programmable logic control blocks, 1 programmable binary-Decimal conversion blocks, 2 programmable compare blocks, 3 programmable arithmetic blocks, easy to develop advanced functions

General Technical Specifications

Input/Output Function	Reference Source	Digit: Keypad, UP/DOWN terminal, preset speed, pulse, communication Analog: AI1: 0V ~ 10V, 0(4)mA ~ 20mA. AI2: 0V ~ 10V
	Operating Mode	Keypad, control terminal, communication
	Digital Input Terminals	DI1 ~ DI7: 7 ways programmable terminals, pos. and nega. is logical optional, and DI6 can be set as pulse input, 0Hz ~ 60Hz; DI7 can be high frequency pulse input (1kHz ~ 50.0kHz) or PTC thermistor input
	Digital Output Terminals	DO1 ~ DO2: 2 ways programmable digital output terminals, Max. output current: 50mA (each way), DO2 can be the terminal to output pulse (0.1kHz ~ 50.0kHz), and output PWM (10kHz)
	Analog Output Terminal	AO1: programmable analog output terminal, 0V-10V, 0(4)mA ~ 20mA.
	Relay output	2 programmable normal open relays, contactor data:AC250V/2A(COSφ=1), AC250V/1A(COSφ=0.4), DC30V/1A
Communication	Interface	RS485, RJ45
	Protocol	Modbus RTU
Environment	Altitude	1000m rated, 1000m-3000m, 1% rated current derating per 100m
	Operation Temperature	-20°C~+40°C (Operation with derating at 40°C~55°C)
	Humidity	<90% RH, no-condensing
	Vibration	<5.9m/s ² (0.6g)
	Storage Temperature	-40°C~+70°C
	Operation Environment	Indoor, no direct sunlight, non-flammable, no corrosive gasses and liquid, no contamination with electrically conductive material
Optional Modules	HV232, HVUSB, Profibus module, keypad pallet, HV-Manager (PC Tools), Three-phase voltage detection module	
Protection Function	Output shortage, over current, over load, over voltage, under Voltage, Phase loss, over heat, external trip, etc.	
Efficiency	1.5kW and below: ≥89% 2.2kW ~ 22kW: ≥93% 30kW and above: ≥95%	
Mounting Method	Cabinet installation, Through panel, surface mounting	
Ingress Protection	IP20, IP21 (by adding optional device)	
Cooling Method	220V/0.4kW(0.5hp) model is nature cool, others are forced air cool	



Model Selection

HV300 – **A0 2 T** **00007** **G** **B**

Series:

HV300: hopeVert series general purpose

Topology and cooling method:

A0: Two-quadrant, air-cooling W0: Two-quadrant, liquid-cooling
A1: Four-quadrant, air-cooling W1: Four-quadrant, liquid-cooling

Voltage level:

2: 220V 4: 380V 6: 690V

Phase:

D: 1 PH or 3 PH T: 3 PH

Power level:

00007: 0.7kW 00075: 7.5kW 00150: 15kW
01850: 185kW 20000: 2MW

Load type:

G: standard G type
E: small size G type
Blank: G/P combined type

Brake unit:

B: Built-in brake unit
Blank: None or external

Dimensions (See the table of product dimensions)



Model Specifications



Power rating of this chapter is referred to the standard 4 poles induction motor.

G, E: Constant torque applications.

P: Variable torque applications such as fans and pumps.

G, E model overload capacity: 150% rated output current, 1 minute

P model overload capacity: 110% rated output current, 1 minute.

220V Models Specifications

Power supply: 220V, 50Hz, 1 phase / 3 phase						
Model	Default carrier frequency (kHz)	Rated capacity (kVA)	Input current (A)	Rated output current (A)	Motor Power (kW)	Size
			1 phase / 3 phase			
HV300-A02D00004GB	6	1.1	7.1/4	2.8	0.4	A
HV300-A02D00007GB	6	1.9	12.8/7.1	5	0.75	A
HV300-A02D00015GB	6	3.0	20.5/11.3	8	1.5	A
HV300-A02D00022GB	6	4.2	24/14.5	11	2.2	B
HV300-A02D00040GB	6	6.7	29/16.5	17.6	4	C

380V Models Specifications

Power supply: 380V, 50Hz, 3 phase										
Model	Default carrier frequency (kHz)	G Type				P Type				Size
		Rated capacity (kVA)	Input current (A)	Rated output current (A)	Motor Power (kW)	Rated capacity (kVA)	Input current (A)	Rated output current (A)	Motor Power (kW)	
HV300-A04T00007GB	6	1.7	3.6	2.5	0.75	-	-	-	-	A
HV300-A04T00015GB	6	2.8	5.7	4.2	1.5	-	-	-	-	A
HV300-A04T00022EB	6	3.4	6.1	5.2	2.2	-	-	-	-	A
HV300-A04T00022GB	6	3.8	8.3	5.8	2.2	-	-	-	-	B
HV300-A04T00040GB	6	6.3	13.2	9.5	3.7	-	-	-	-	B
HV300-A04T00055EB	3	8.6	14.3	13	5.5	-	-	-	-	B
HV300-A04T00055GB	6	8.6	12.4	13	5.5	-	-	-	-	C
HV300-A04T00075GB	6	11	16.1	17	7.5	-	-	-	-	C
HV300-A04T00110B	6	16.5	24	25	11	21	31	32	15	D
HV300-A04T00150B	6	21	31	32	15	25	36	38	18.5	D
HV300-A04T00185B	6	25	36	38	18.5	30	44	46	22	E
HV300-A04T00220B	6	30	44	46	22	40	58	60	30	E
HV300-A04T00300E(B)	3	40	58	60	30	50	72	75	37	E1
HV300-A04T00370E(B)	3	50	72	75	37	-	-	-	-	E1
HV300-A04T00300(B)	3	40	58	60	30	50	72	75	37	F
HV300-A04T00370(B)	3	50	72	75	37	63	93	96	45	F
HV300-A04T00450(B)	3	63	93	96	45	83	121	125	55	F
HV300-A04T00450E(B)	3	63	93	96	45	-	-	-	-	F1
HV300-A04T00550(B)	3	83	121	125	55	103	151	156	75	F

380V Models Specifications

Power supply: 380V, 50Hz, 3 phase										
Model	Default carrier frequency (kHz)	G Type				P Type				Size
		Rated capacity (kVA)	Input current (A)	Rated output current (A)	Motor Power (kW)	Rated capacity (kVA)	Input current (A)	Rated output current (A)	Motor Power (kW)	
HV300-A04T00750(B)	3	103	151	156	75	119	175	180	90	F
HV300-A04T00900(B)	3	119	175	180	90	139	204	210	110	G
HV300-A04T01100(B)	3	139	204	210	110	169	248	256	132	G
HV300-A04T01320(B)	3	169	248	256	132	205	301	310*	160	G
HV300-A04T01600(B)	3	205	301	310	160	231	340	350	185	J
HV300-A04T01850(B)	3	231	340	350	185	255	375	387	200	J
HV300-A04T02000(B)	3	255	375	387	200	280	415	427	220	J
HV300-A04T02500(B)	2	310	457	471	250	343	505	520	280	K
HV300-A04T02800(B)	2	343	505	520	280	403	592	610	315	K
HV300-A04T03150(B)	2	403	592	610	315	444	653	673	355	K
HV300-A04T03550(B)	2	444	653	673	355	495	728	750	400	L
HV300-A04T04000(B)	2	495	728	750	400	551	810	835	450	L
HV300-A04T04500(B)	2	551	810	835	450	622	915	943	500	L
HV300-A04T05000G(B)	2	645	960	990	500	-	-	-	-	L

690V Models Specifications

Power supply: 690V, 50Hz, 3 phase										
Model	Default carrier frequency (kHz)	G Type				P Type				Size
		Rated capacity (kVA)	Input current (A)	Rated output (A)	Motor Power (kW)	Rated capacity (kVA)	Input current (A)	Rated output current (A)	Motor Power (kW)	
HV300-A06T00300(B)	3	43	36	36	30	51	42	43	37	F
HV300-A06T00370(B)	3	51	42	43	37	65	52	54	45	F
HV300-A06T00450(B)	3	65	52	54	45	75	61	63	55	F
HV300-A06T00550(B)	3	75	61	63	55	103	83	86	75	F
HV300-A06T00750(B)	3	103	83	86	75	120	97	100	90	F
HV300-A06T00900(B)	3	120	97	100	90	157	127	131	110	G
HV300-A06T01100(B)	3	157	127	131	110	179	145	150	132	G
HV300-A06T01320(B)	3	179	145	150	132	209	170	175*	160	G
HV300-A06T01600(B)	3	209	170	175	160	237	192	198	185	J
HV300-A06T01850(B)	3	237	192	198	185	276	224	231	200	J
HV300-A06T02000(B)	3	276	224	231	200	296	235	248	220	J
HV300-A06T02500(B)	2	327	266	274	250	350	285	293	280	K
HV300-A06T02800(B)	2	350	285	293	280	392	318	328	315	K
HV300-A06T03150(B)	2	392	318	328	315	462	375	387	355	L
HV300-A06T03550(B)	2	462	375	387	355	509	413	426	400	L
HV300-A06T04000(B)	2	509	413	426	400	576	468	482	450	L
HV300-A06T04500(B)	2	576	468	482	450	651	529	545	500	L

*Note: 1. The model with "B" means this model has built-in brake unit, without "B" means without built-in brake unit, please pays attention to it when select the model.

(1) For 22kW and below models, built-in brake unit is standard configuration.

(2) For 30kW and above models, brake unit is optional. Please remove the "B" of the model if you don't need the brake unit when ordering.

2. When HV300-A06T01320 and HV300-A06T03150 is used as P type, the default carrier frequency is 1kHz.

3. 5.5kW ~ 280kW models (including 220V/4kW, except E type) are fitted with DC reactor for standard; 5.5kW ~ 45kW are fitted with built-in reactor, 55kW and above are fitted with external reactor. 315kW ~ 450kW models are fitted with input AC reactor for standard.

Brake Resistor Specifications

The selection of the brake resistor is depends on the motor power in actual application, and also relative to system inertia, deceleration time and other factors. User can choose it according to actual situation.

Model	Min. brake resistor (Ω)	Max. brake current (A)	Max. instant Power (kW)	Recommended resistor (Ω)
HV300-A02D00004GB	41	10	4.15	82
HV300-A02D00007GB	41	10	4.15	82
HV300-A02D00015GB	41	10	4.15	82
HV300-A02D00022GB	20	21	8.48	40
HV300-A02D00040GB	12	35	14.3	24
HV300-A04T00007GB	120	7	5.67	240
HV300-A04T00015GB	120	7	5.67	240
HV300-A04T00022EB	65	13	10.4	130
HV300-A04T00022GB	65	13	10.4	130
HV300-A04T00040GB	50	17	13.5	100
HV300-A04T00055EB	24	35	28.7	48
HV300-A04T00055GB	24	35	28.7	48
HV300-A04T00075GB	24	35	28.7	48
HV300-A04T00110B	24	35	28	48
HV300-A04T00150B	17	50	40	34
HV300-A04T00185B	17	50	40	34
HV300-A04T00220B	17	50	40	34
HV300-A04T00300(B)	11	75.5	55.3	22
HV300-A04T00300E(B)	11	75.5	55.3	22
HV300-A04T00370E(B)	11	75.5	55.3	22
HV300-A04T00370(B)	11	75.5	55.3	22
HV300-A04T00450(B)	9	92	67.6	18
HV300-A04T00450E(B)	9	92	67.6	18
HV300-A04T00550(B)	7	120	86.9	14
HV300-A04T00750(B)	7	120	86.9	14
HV300-A04T00900(B)	4.2	200	164	8.4
HV300-A04T01100(B)	2.8	300	246	5.6
HV300-A04T01320(B)	2.8	300	246	5.6
HV300-A04T01600(B)	1.8	450	357	3.6
HV300-A04T01850(B)	1.8	450	357	3.6
HV300-A04T02000(B)	1.8	450	357	3.6

HV300-A04T02500(B)	1.4	600	493	2.8
HV300-A04T02800(B)	1.4	600	493	2.8
HV300-A04T03150(B)	0.9	900	765	1.8
HV300-A04T03550(B)	0.9	900	765	1.8
HV300-A04T04000(B)	0.7	1200	984	1.4
HV300-A04T04500(B)	0.7	1200	984	1.4
HV300-A04T05000G(B)	0.7	1200	984	1.4
HV300-A06T00300(B)	13	92	95	26
HV300-A06T00370(B)	13	92	95	26
HV300-A06T00450(B)	13	92	95	26
HV300-A06T00550(B)	10	119	125.5	20
HV300-A06T00750(B)	10	119	125.5	20
HV300-A06T00900(B)	8	150	177	16
HV300-A06T01100(B)	8	150	177	16
HV300-A06T01320(B)	5.3	225	267	10.6
HV300-A06T01600(B)	5.3	225	267	10.6
HV300-A06T01850(B)	5.3	225	267	10.6
HV300-A06T02000(B)	4	300	353	8
HV300-A06T02500(B)	4	300	353	8
HV300-A06T02800(B)	2.7	450	535	5.4
HV300-A06T03150(B)	2.7	450	255	5.4
HV300-A06T03550(B)	2	600	344	4
HV300-A06T04000(B)	2	600	344	4
HV300-A06T04500(B)	1.3	900	530	2.6



Dimensions

Size	Model	W (mm)	W1 (mm)	W2 (mm)	H (mm)	H1 (mm)	D (mm)	D1 (mm)	Mounting hole Φ	Net weight (kg)
A	HV300-A02D00004GB	97.4	80	-	202.4	190	148.8	-	5	1.4
	HV300-A02D00007GB									
	HV300-A02D00015GB									
	HV300-A04T00007GB									
	HV300-A04T00015GB									
	HV300-A04T00022EB									
B	HV300-A02D00022GB	142.4	123.5	-	220.4	208	155.5	-	5	2.2
	HV300-A04T00022GB									
	HV300-A04T00040GB									
	HV300-A04T00055EB									
C	HV300-A02D00040GB	163.1	142	-	300	280	176.8	-	6	4.5
	HV300-A04T00055GB									
	HV300-A04T00075GB									
D	HV300-A04T00110B	238.5	184	92	370	356.5	189	-	7	8.8
	HV300-A04T00150B									
E	HV300-A04T00185B	238.5	184	92	435.5	422	200.3	-	7	12.1
	HV300-A04T00220B									
E1	HV300-A04T00300E(B)	320	210	-	510	490	226	222.5	8	20
	HV300-A04T00370E(B)									
F	HV300-A04T00300(B)	355.5	221	-	573	552.5	315.5	310	10	40
	HV300-A04T00370(B)									
	HV300-A04T00450(B)									
	HV300-A04T00550(B)									
	HV300-A04T00750(B)									
	HV300-A06T00300(B)									
	HV300-A06T00370(B)									
	HV300-A06T00450(B)									
	HV300-A06T00550(B)									
	HV300-A06T00750(B)									
F1	HV300-A04T00450E	355.5	221	-	573	552.5	296.9	280.7	10	33

Size	Model	W (mm)	W1 (mm)	W2 (mm)	H (mm)	H1 (mm)	D (mm)	D1 (mm)	Mounting hole Φ	Net weight (kg)
G	HV300-A04T00900(B)	445.6	340	170	725	701.5	355	349.5	10	63
	HV300-A04T01100(B)									
	HV300-A04T01320(B)									
	HV300-A06T00900(B)									
	HV300-A06T01100(B)									
	HV300-A06T01320(B)									
J	HV300-A04T01600(B)	575.5	440	220	937	889	379.3	373.8	13	104
	HV300-A04T01850(B)									
	HV300-A04T02000(B)									
	HV300-A06T01600(B)									
	HV300-A06T01850(B)									
HV300-A06T02000(B)										
K	HV300-A04T02500(B)	640	520	175	1246.5	1207.5	405.5	400	13	150
	HV300-A04T02800(B)									
	HV300-A06T02500(B)									
	HV300-A06T02800(B)									
	HV300-A04T03150(B)									
L	HV300-A04T03550(B)	804	-	-	2200	-	804	-	-	350
	HV300-A04T04000(B)									
	HV300-A04T04500(B)									
	HV300-A06T03150(B)									
	HV300-A06T03550(B)									
	HV300-A06T04000(B)									
	HV300-A06T04500(B)									
	HV300-A04T05000G(B)									



Control Connection

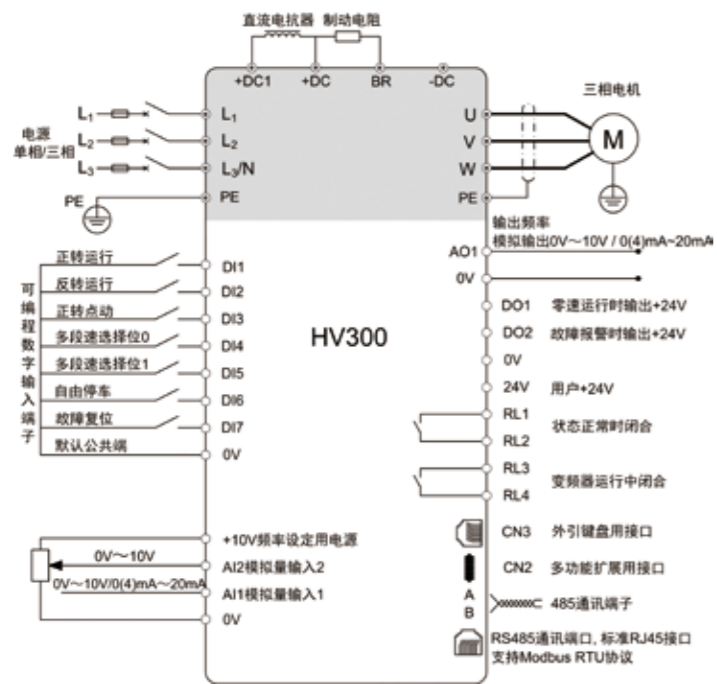

Switching Input (1ms)

- 7 ways DI, can be adapted to various peripherals (source is chosen by electrical switch).
- DI7 can be high frequency pulse input (50k).
- DI7 can be PTC motor protection (5ms).

Communication Interface

- Dual RS485 interface, optional RJ45 or A, B terminal.

Switching Output (20ms)

- Dual RS485 interface, optional RJ45 or A, B terminal.
- 2 ways relay output.

Analog Input/ Output (5ms)

- Dual analog input, optional offline protection.
- 1 way output (optional 0 ~ 10V/0 ~ 20mA).

Mechanical Mounting

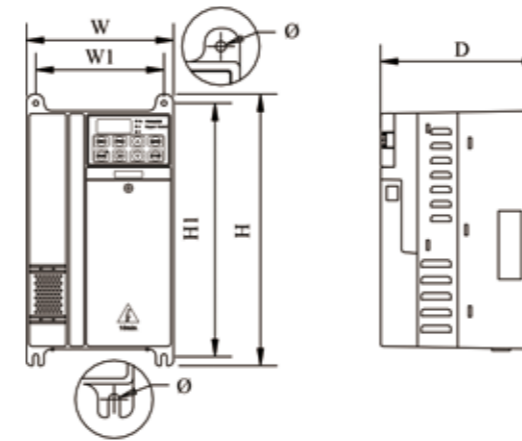

Size A/B/C

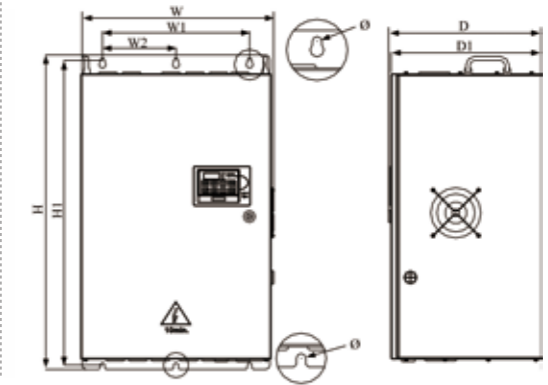

Size G

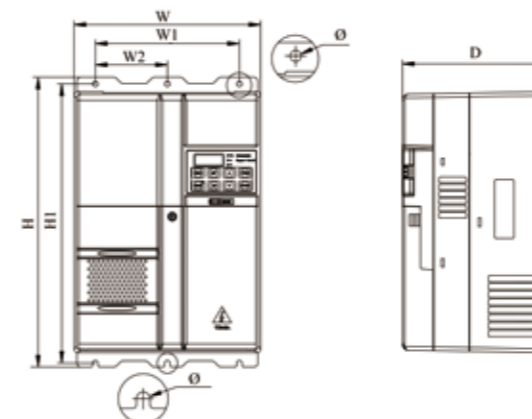

Size D/E

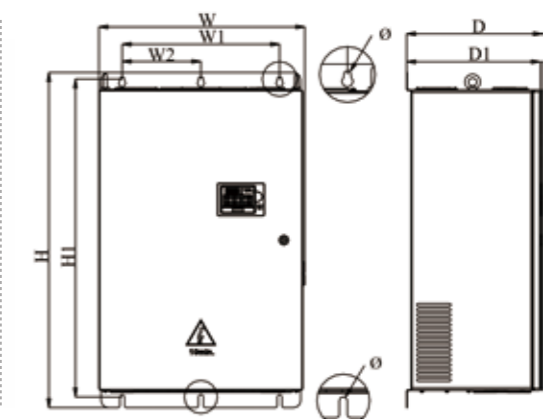

Size J/K

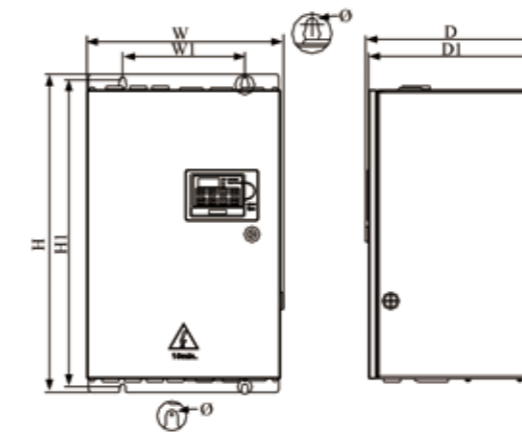

Size E1/F/F1

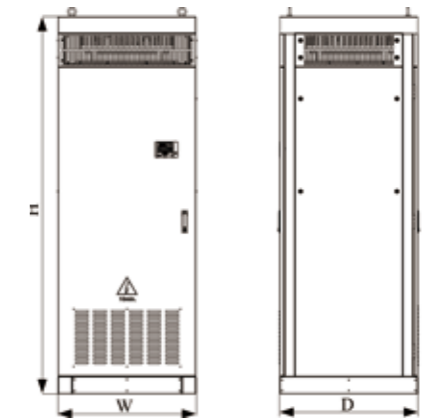

Size L

External DC Reactor Dimensions

380V Reactor Dimensions

Model	w (mm)	w1 (mm)	d (mm)	d1 (mm)	h (mm)	h1 (mm)	f (mm)	Mounting hole R*L (mm)	Copper connection hole K	Net weight (kg)
HV300-A04T00550(B)	167	130	153.5	95	163.5	131	158.5	10*15	Φ9	10.3
HV300-A04T00750(B)										
HV300-A04T00900(B)	190	160	153	117	245	192	180	10*15	Φ12	20
HV300-A04T01100(B)										
HV300-A04T01320(B)										
HV300-A04T01600(B)	190	160	148	115	245	192	250	10*20	Φ13	25
HV300-A04T01850(B)										
HV300-A04T02000(B)										
HV300-A04T02500(B)	275	210	240	205	235	-	240	11*18	Φ14	38
HV300-A04T02800(B)										
HV300-A04T03150(B)										

690V Reactor Dimensions

Model	w (mm)	w1 (mm)	d (mm)	d1 (mm)	h (mm)	h1 (mm)	f (mm)	Mounting hole R*L (mm)	Copper connection hole K	Net weight (kg)
HV300-A06T00550(B)	128	130	116	90	180	140	175	10*15	Φ9	10
HV300-A06T00750(B)										
HV300-A06T00900(B)	190	160	153	117	245	192	180	10*15	Φ12	20
HV300-A06T01100(B)										
HV300-A06T01320(B)										
HV300-A06T01600(B)	190	160	148	115	245	192	250	10*20	Φ13	25
HV300-A06T01850(B)										
HV300-A06T02000(B)										
HV300-A06T02500(B)	235	180	230	175	205	-	230	11*18	Φ14	27.5
HV300-A06T02800(B)										

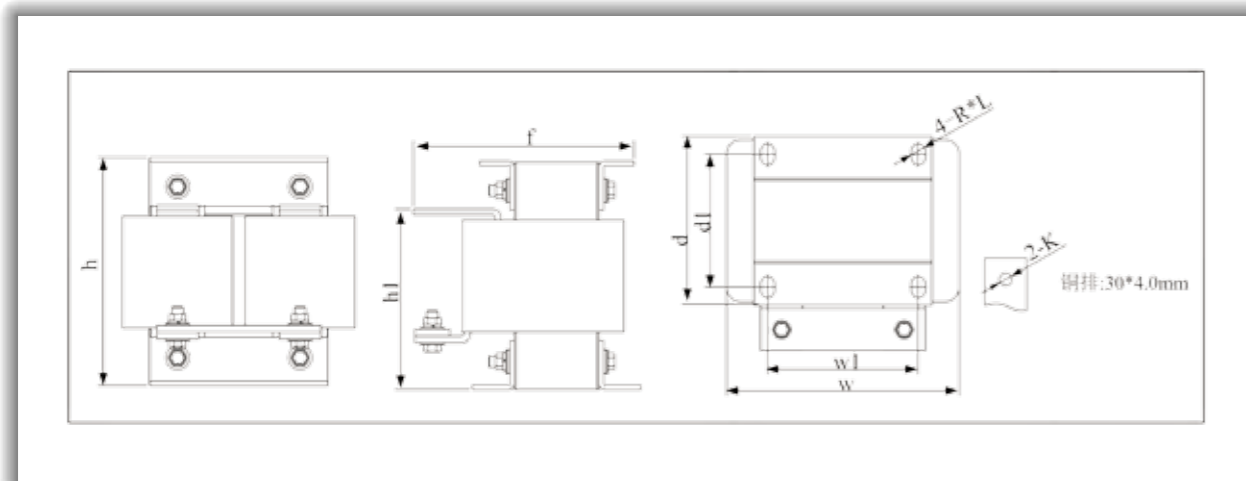

Cable for DC Reactor

380V DC Reactor Cable Specifications

Model	Cable current (A)	Cable voltage (V)	Cable area (mm ²)
HV300-A04T00550(B)	154	500VDC	70
HV300-A04T00750(B)	185	500VDC	120
HV300-A04T00900(B)	226	500VDC	150
HV300-A04T01100(B)	272	500VDC	185
HV300-A04T01320(B)	329	500VDC	120*2
HV300-A04T01600(B)	381	500VDC	120*2
HV300-A04T01850(B)	412	500VDC	120*2
HV300-A04T02000(B)	514	500VDC	150*2
HV300-A04T02500(B)	576	500VDC	150*2
HV300-A04T02800(B)	648	500VDC	150*3
HV300-A04T03150(B)	729	500VDC	150*3

690V DC Reactor Cable Specifications

Model	Cable current (A)	Cable voltage (V)	Cable area (mm ²)
HV300-A06T00550(B)	85	1000VDC	25
HV300-A06T00750(B)	102	1000VDC	35
HV300-A06T00900(B)	125	1000VDC	50
HV300-A06T01100(B)	150	1000VDC	70
HV300-A06T01320(B)	182	1000VDC	50*2
HV300-A06T01600(B)	211	1000VDC	70*2
HV300-A06T01850(B)	228	1000VDC	70*2
HV300-A06T02000(B)	285	1000VDC	90*2
HV300-A06T02500(B)	319	1000VDC	120*2
HV300-A06T02800(B)	358	1000VDC	120*2



Product Features

Intelligent IGBT module heat protection design

- Built-in dynamic junction temperature model, Monitor IGBT junction temperature in real time.
- Unique short-circuit and circuit through protection technology, protect system security.
- Delay overcurrent protection reset, suppress overcurrent .



Adaptive IGBT drive control stability design

- Hopewind self-developed IGBT module stability design platform.
- Able to obtain main parameters in the IGBT open/close process, to evaluate the function and performance of IGBT drive board.
- Able to evaluate the reasonableness of IGBT module design, to ensure the design of product power system is safe and reliable, guarantee the stable operation of power system.

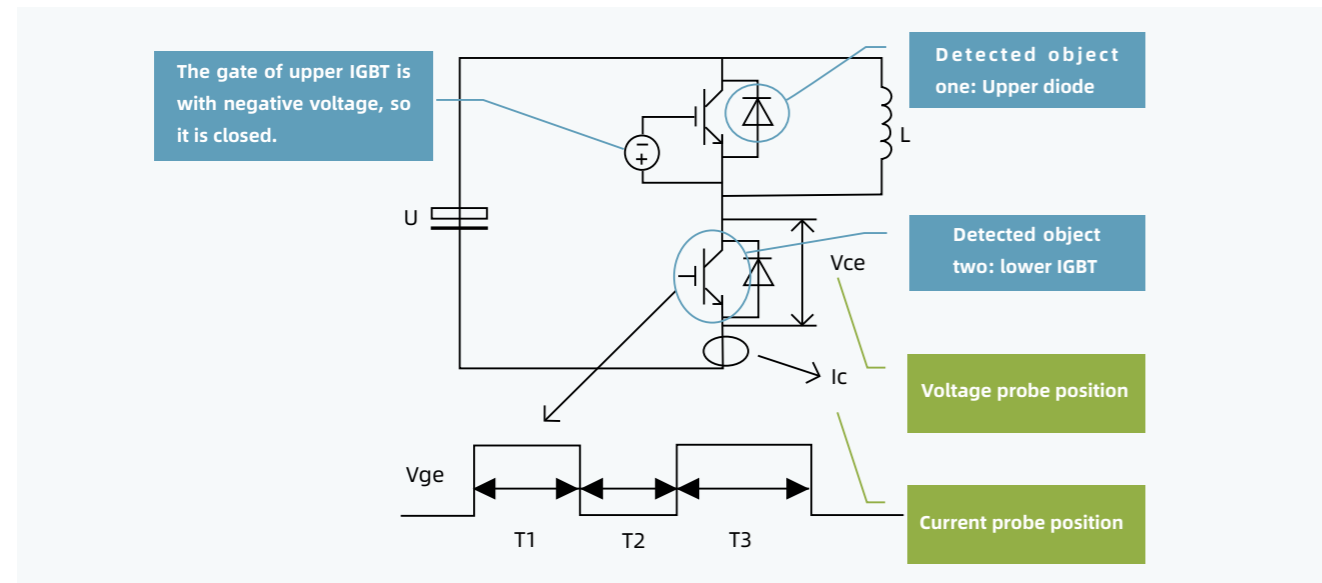

Powerful PC tools - HVManager, provide programming, setting, debugging, monitoring and other functions

- Monitor the VFD status in real time.
- Comprehensive parameter setting function, easy to debug by user.

All series have built-in EMC filter (user can choose)

Note: User can disconnect EMC filter by the short sheet in the image, mainly used in the situation which require the installation of RCD and the leakage current lower than 30mA.



Function modular design, has both advantages of European models and Japanese models

- Easy to setting like Japanese models, also has strong functional expansions like European models.

Dual RS485 interface, optional A, B interface and RJ45 interface



4kW and above models are configured DC reactor as standard

- Decrease 50% of current distortion rate.
- Inhibit impact from grid, protect rectifier bridge.
- Increase the power factor of input side.
- Increase the overall efficiency and heat stability of the VFD.
- Inhibit the effect from higher harmonics of input side to the VFD, decrease external transmission and radiation interference.

Profibus communication

- Convenient communication setting.
- Good environmental adaptability.
- Support five PPO data communication format (PPO1 ~ PPO5).

Built-in powerful logic and arithmetic modules, support custom DIY for special functions

- Built-in simplified PLC, control terminals can be customize, user can design operation mode according to his special requirement.

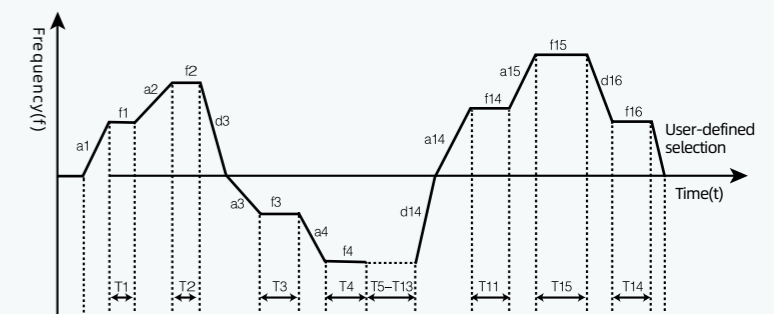

Can set DI terminals leakage and source mode by function code

- DI input common port can choose 0V or 24V, the factory default value is 0V, user can select by setting parameter P09.21; P09.21 = 0 means the common port is 0V, P09.21 = 1 means the common port is 24V.

Built-in PID control module

- Realize the close loop control of temperature, pressure, flow and other signals, increase the stability and accuracy of production.

Can drive two different motor in vector control mode

- Can store two sets of motor parameter, and can switch flexibility in the situation which need not to run two motors in the same time, to save the cost, reduce the space occupation.

Options

Options	Model	Function and Usage
Keypad pallet	HVPFT-S	Can install the pallet at the specified position according to site needs, remote control the VFD by keypad
Communication adapter	HV232	Realize the two-way isolation conversion of RS-232 and RS-485 signal. VFD can realize the high speed data communication with computer by this option
Communication adapter	HVUSB	Realize the two-way isolation conversion of USB and RS-485 signal. VFD can realize the high speed data communication with computer by this option
Profibus module	HVFPB	Profibus module is a import option of HV300 series VFD, is used to provide profibus-DP slave connectivity to realize the main station control, monitor and diagnose the VFD
I/O terminal expansion module	HVIOU	As the I/O terminal expansion module of the VFD, can expansion the input/output terminals to satisfy different function required by custom
Three-phase voltage detection module	HVVMU	Detection of three-phase voltage, participation in control, can be used for permanent magnet synchronous motor soft-start grid-connection, speed tracking and other functions



- Hopewind HV300 series VFDs are configured with LED keypad as standard, the remote keypad is optional. All expansion modules of Hopewind (including I/O module, communication module, function module) are shell packaged, relate to traditional PCB expansion module, it can increase the protect level of the expansion module, also easy to install, just insert the module in the slot.

Built-in Function module

The VFD has a powerful built-in function edit platform, easy for user to develop advanced functions. The specific blocks are shown below:

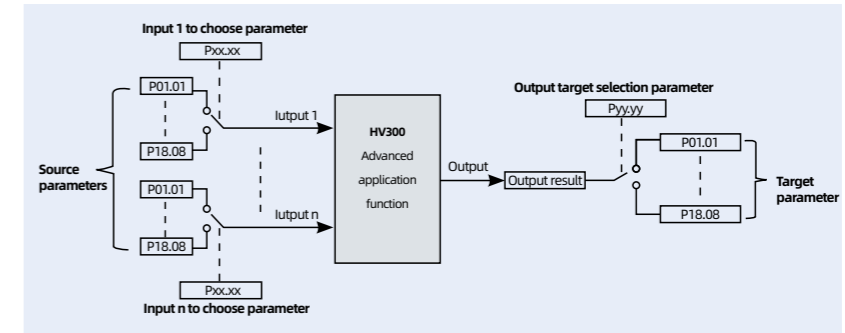
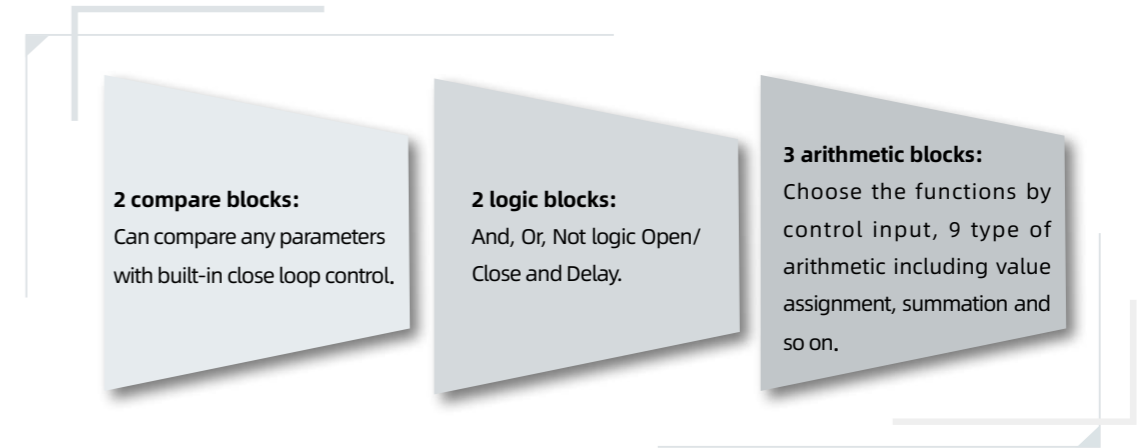

Only input corresponding function parameter to realize the required function, easy to use

Case (Acce./Dece. rate auto switch)

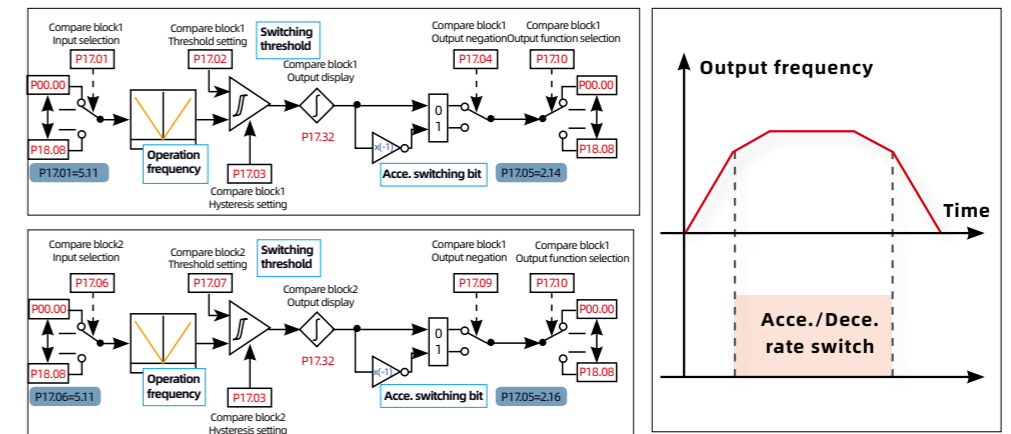

Example:

- Set P17.01=5.11 (Operation frequency), P17.02=70% (Threshold, 70% of max. frequency), P17.05=2.14 (Acce. rate selection bit 0), P17.06=5.11 (Operation frequency), P17.07=80% (Threshold, 80% of max. frequency), P17.10=2.16 (Dece. rate selection bit 0).
- Assume the max. operation frequency is 50Hz, when the VFD accelerate to $50 \times 70\% = 35\text{Hz}$, the accelerate rate switched from rate 0 to rate 1; when the VFD decelerate to $50 \times 80\% = 40\text{Hz}$, the decelerate rate switched from rate 0 to rate 1.

Programming Interface

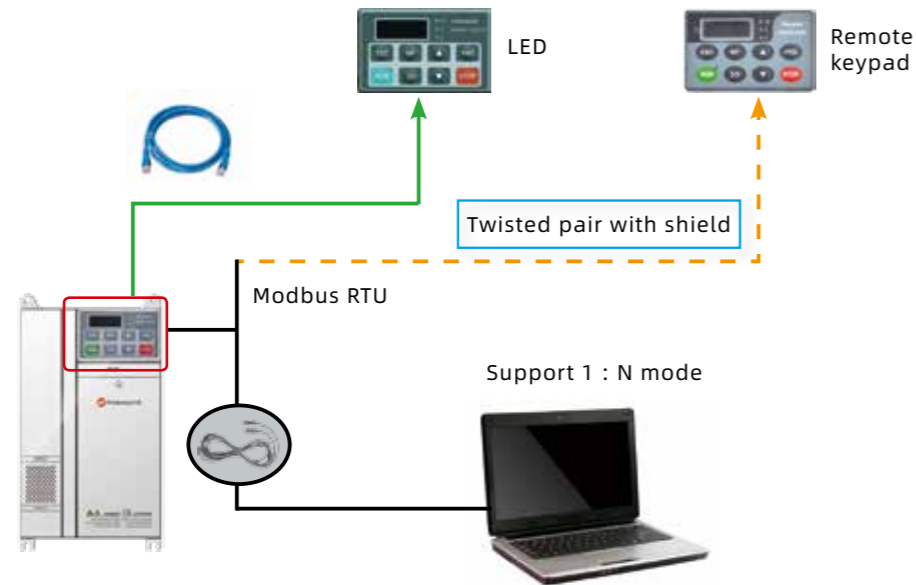

User can choose LED or remote keypad to control the VFD. At the same time, the HV-Manager software developed by Hopewind can be installed in the host computer on site to view the status of the VFD in real time.

The HV-Manager is a easy-to-use host monitor software, support VFD parameter operation and virtual oscilloscope, the virtual oscilloscope can realize the graphical monitoring of VFD internal status, real time tracking and fault location, make programming and debugging easier, convenient for background analysis and engineering management.

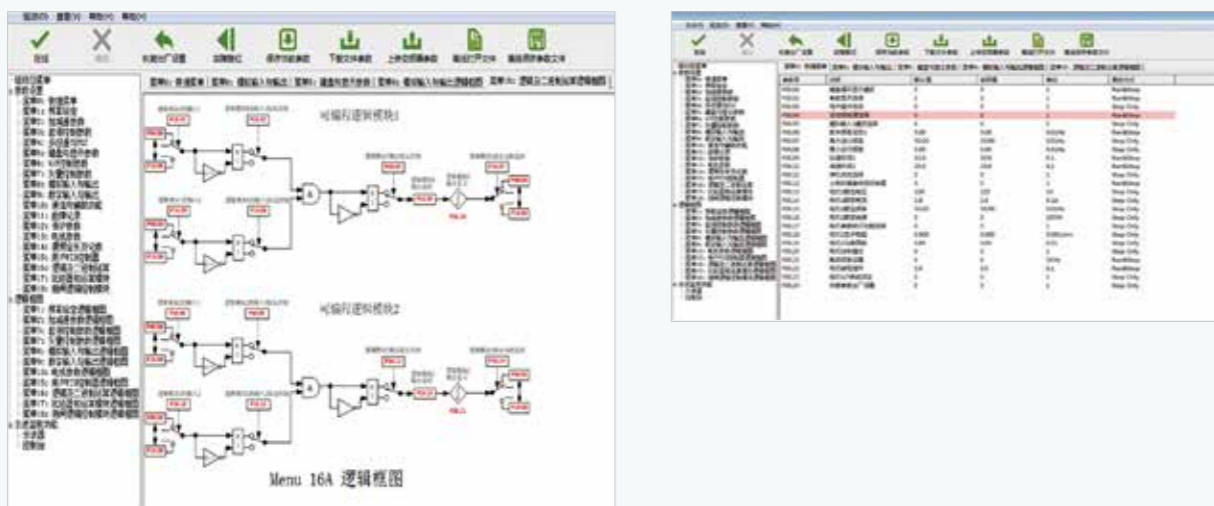

Typical Application

Oilfield pumping unit

Application Situation

Location: An oilfield.

Power: 22kW.

Effect: Save more than 30% power, avoid the impact from overcurrent to grid and equipment.

Technical advantage

Wide voltage range, strong adaptability to harsh grid Low starting current, smooth speed, small impact to grid Built-in EMC filter, standard configured DC reactor, low radiation.



Steel plant roller

Application Situation

Location: A steel plant in Tianjin.

Power: 22kW, 30kW, 37kW, 45kW.

Effect: Stable operation, fault rate < 1%.

Technical advantage

Adapt to reciprocating acceleration and deceleration operation.

Long - term continuous operation.

Adapt to high temperature and high protection requirements in steel workshops

Support Profibus DP network.



Steel plant cold saw

Application Situation

Location: A steel plant in Tangshan.

Power: 450kW.

Effect: High overload operation, stable speed control, meets process requirements.

Technical advantage

High overload ability.

High speed response ability.

Adapt to high temperature and high protection requirements in steel workshops.

Support Profibus DP network.



R&D strength



- Cumulative investment to R&D **Over 500 million** yuan
- The average product development experience of core technical team is **more than 15 years**

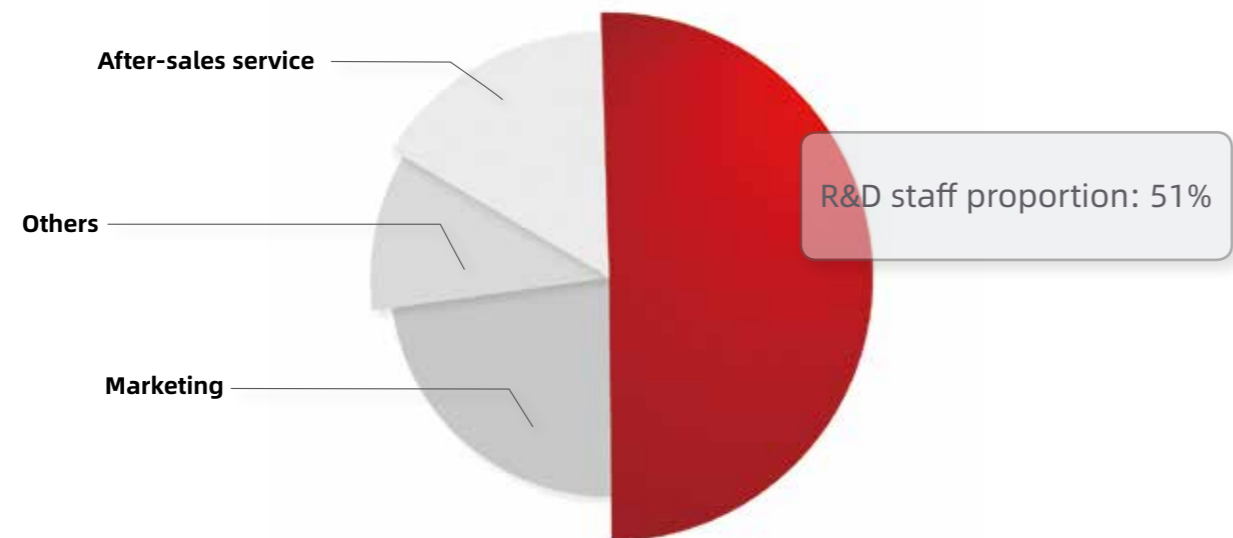

Certifications

Hopewind is the leading team of the VFD manufacturers who pass UL certification in the domestic industry.



UL is the safety sign which most trusted by American consumers, also the most professional and most strict safety certification in the world. When most of domestic VFDs are dare not to challenge the UL, we have passed it easily.

Full series pass CE and ROHS certification.



Laboratory establishes cooperative relationship with a number of third party testing institutions with professional qualifications, including TUV, Intertek, TTS, MORLAB, CCIS, Intertek, TTS, MORLAB, CCIS, CGC, CQC, SMQ, etc.



Hopewind VFDs pass TUV certification



Laboratory is awarded the ILAC - MAR/ CNAS qualification



Building 11, Guanlong No.2 Industry Park, Xili Town,
Nanshan District, Shenzhen, China, 518055
Tel: +86-755-86026786, Shenzhen (Headquarters)
+86-10-82193180, Beijing (Office)
400-8828-705, Hotline
en.hopewind.com

©2021: hopewind
All rights reserved V4.2.1

If there is any change in product size and parameters, they shall be subject to the latest actual product

