

HOPEWIND



HD2000 Series Low Voltage Engineering Single-Drive/ Multi-Drive Variable Frequency System

Shenzhen Hopewind Electric Co., Ltd. (Stock Code: 603063) focuses on the R&D, manufacturing, sales and services of renewable energy & electric drive products, including products for wind power generation, photovoltaic generation, energy storage, hydrogen production power supply, power quality and electric drive. Furthermore, Hopewind owns integrated independent R&D and testing platforms of high-power power electrical equipment and monitoring systems. Through innovation in technology and service, Hopewind continuously creates value for customers, and has become one of China's most competitive enterprises in the renewable energy field.

In the field of industrial drive, Hopewind provides a wide range of inverters with various voltage and power classes, mainly including HV350 series low-voltage general purpose inverter, HV510 series low-voltage high-performance inverter, HV500 series low-voltage engineering single transmission inverter, HD2000 series low-voltage engineering inverter, HD8000 series medium-voltage engineering inverter, etc., and also provides solutions for 0.75kW~22400kW low-voltage inverter and 8MVA~136MVA medium-voltage inverter. These products can be widely used in metallurgy, petroleum and petrochemical, mining machinery, port lifting, distributed energy generation, large-scale testing platforms, marine equipment, textiles, chemicals, cement, municipal and various other industrial applications.

【Honors】



National Science and Technology Progress Award



Laboratory Qualification Approved by CNAS



National High-tech Enterprise

【Quality System】



Quality Management System



Environmental Management System



Occupational Health and Safety Management System

Headquarter-Shenzhen

4 major R&D and manufacturing bases: Shenzhen, Suzhou, Xi'an, Heyuan

30 service bases: Deployed worldwide and providing comprehensive services for global customers



Contents



HD2000 Series Low Voltage Engineering Variable Frequency Drive System 04

Product Overview 04

Description 04

Typical Application 05

Single-/Multi-Drive Concept Diagram 05

Product Features of HD2000 Series Variable Frequency Drives 06

hopInsight Background Rapid Commissioning Software 07

Performance Advantages 08

Reliability Assurance 11

HD2000 Series Product Classifications 12

Application Cases 12

Technical Specifications of HD2000 Series Products 13

HCU20 Control Unit 14

Operator Panel 16

Encoder Module 16

HD2000 Unit Selection (Air-Cooled) 16

HD2000 Cabinet Selection (Air-Cooled) 24

HD2000 Unit Selection (Liquid-Cooled) 32

The HD2000 liquid-cooled Unit Cabinet Selection Table 40

Optional Components 41

HD2000 Configuration Modes 42

HD2000 Series Low Voltage Engineering Variable Frequency Drive System

Product Overview

The HD2000 inverter (hereafter referred to as "the HD2000") is an engineering single-/multi-drive system independently developed by Hopewind Electric. Its modular hardware and engineering software design enables it to handle various complex drive scenarios.

The HD2000 includes single-drive AC-DC-AC variable frequency drive units and DC/AC common DC bus multi-drive motor drive units, both of which are available in cabinets.

The control unit, HCU20, supports vector control and V/F control modes. It is capable of simultaneously driving 3 vector or 8 V/F axes and enabling parallel connection of 8 power units.

- **Key features:** Single-/multi-drive system in the form of units/cabinets with two/four quadrants
- **Modular design:** application flexibility and comprehensive system integration
- **Comprehensive rectifier units:** Basic/Smart/PWM rectifier unit
- **Voltage Levels:** 400V, 690V, 1140V, 1380V
- **Max. single unit power:** 1400kW (Air-cooled), 2800kW (Liquid-cooled)
- **Max. parallel operation power:** 11200kW (Air-cooled), 22400kW (Liquid-cooled)
- **Motors supported:** Asynchronous induction motors, permanent magnet synchronous motors, synchronous reluctance motors
- **Control modes:** V/F, Closed-loop vector control (CLVC), open-loop vector control (OLVC)
- **Cooling modes:** Air-Cooled (Standard configuration), liquid-cooled (L)



Description

HD2000 - 10 B 0500 4 B L -S +L +Q

Series Name:

HD2000: Series low voltage engineering single-drive/multi-drive variable frequency system

Topology/Function:

10: Basic rectifier (Diode) 11: Basic rectifier (SCR)
 12: Smart rectifier 13: PWM rectifier 14: LCL filter interface (No built-in main contactor) 15: LCL filter interface (Built-in main contactor) 16: Motor drive 17: Control 18: Centralized brake 19: Distributed brake 21: Output inductor (1 unit/cabinet) 22: Output inductor (2 units/cabinet) 30: Incoming for distribution 33: Basic rectifier and frequency regulation

Structure Type:

B: Unit product D: Cabinet product

Rated Current:

0500: 500A

Voltage Level:

4: 400V (380V~480V) 6: 690V (500V~690V) 9: 1140V A: 1380V

Braking Options:

B: Built-in brake Null: No built-in brake

Cooling Method:

L: Liquid-cooled Null: Air-cooled

Motor Drive Unit Type:

S: Compact type Null: Chassis type

Output Inductor Options:

+L: Included Null: Not included

DC Bus Switch Options:

+Q: Included Null: Not included

Typical Application



Metallurgy



Petroleum Drilling



Lifting Equipment



Mining Machinery



Marine Equipment



Test Benches



Papermaking



Machine Tools



Ustomized Power Supplies



Rail Transit

Single-/Multi-Drive Concept Diagram

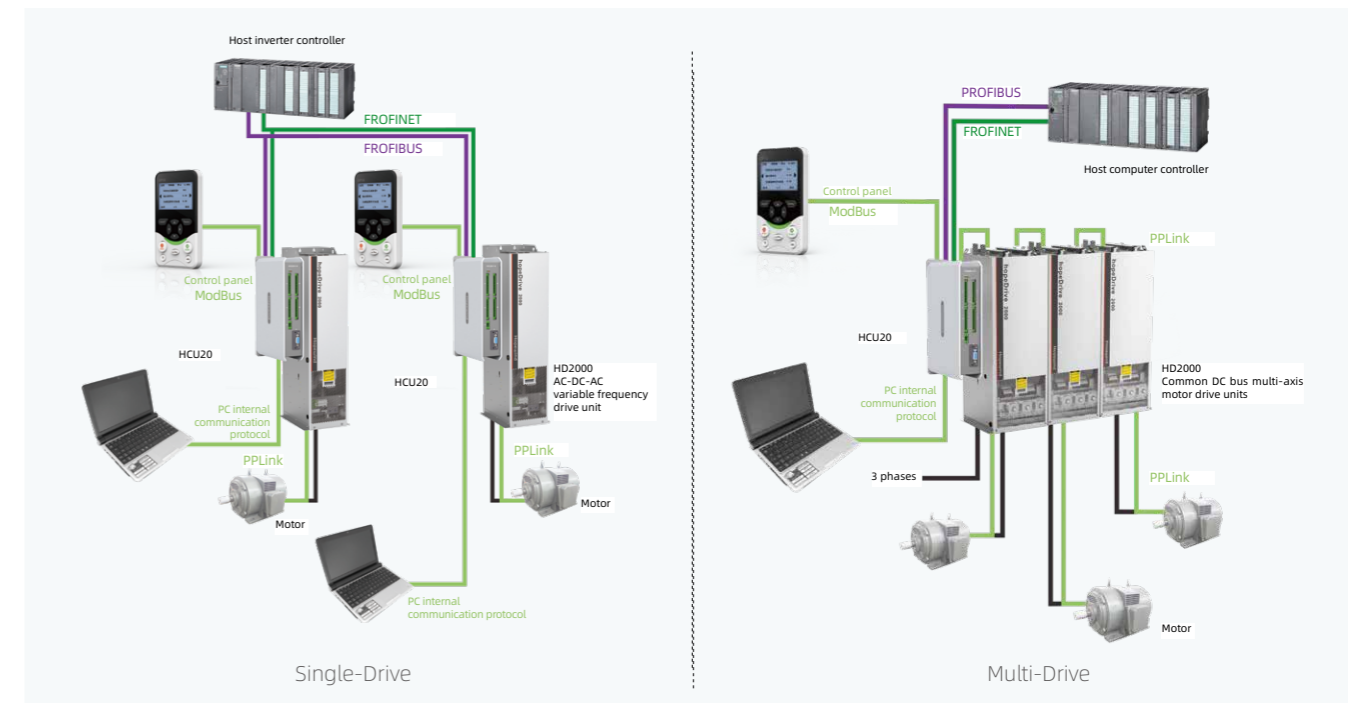

HD2000 Series Low Voltage Engineering Variable Frequency Drive System

Product Features of HD2000 Series Variable Frequency Drives

Reliable Engineering Design

- Highly redundant control and power systems
- Extended lifespan of quick-wear heat dissipation parts (fans, capacitors, etc.)
- Innovative high thermal capacity radiator to withstand strong impact loads
- Optical fiber cables used for control system and power units for resistance to interference
- Isolation of heat dissipation channels from internal components to protect components and better adapt to environment

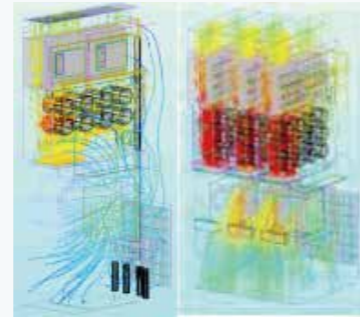

Modular Design for Easy Maintenance

- Easy maintenance as no special tools needed
- Enabling all modules to be maintained from the front
- Intelligent fault diagnosis system to locate faults quickly

High-Strength Anti-Seismic Design

- Normal operation under IEC 60721 class 3M5 mechanical conditions
- Precise mechanical design for stronger anti-seismic capability

Customizable Communication Protocols

- Supported via optional modules for seamless connection with existing PLC, facilitating replacement and maintenance
- Including profibus-DP, CANopen, profinet IO, modbus RTU, modbus TCP, etherCAT, etherNet/IP, controlNet and deviceNet, achieving interconnectivity of industrial devices

Rich Tools for Human-Machine Interaction

- Configurable LCD keypad panel supporting setting parameters and displaying system information
- Supporting connection to hopelnsight via PC for intelligent fault recording and diagnosis

hopelnsight Background Rapid Commissioning Software

hopelnsight is a rapid commissioning tool developed by Hopewind Electric for drive systems. It can be connected to PC background through optical fiber cables. The software offers a wide range of debugging functions, including batch parameter settings, fault data downloading and waveform analysis, high-speed oscilloscope and editing. It supports communication through serial port or Ethernet, thus users can maintain the inverter via serial port or Ethernet in the central control room. The working schematic is as follows:

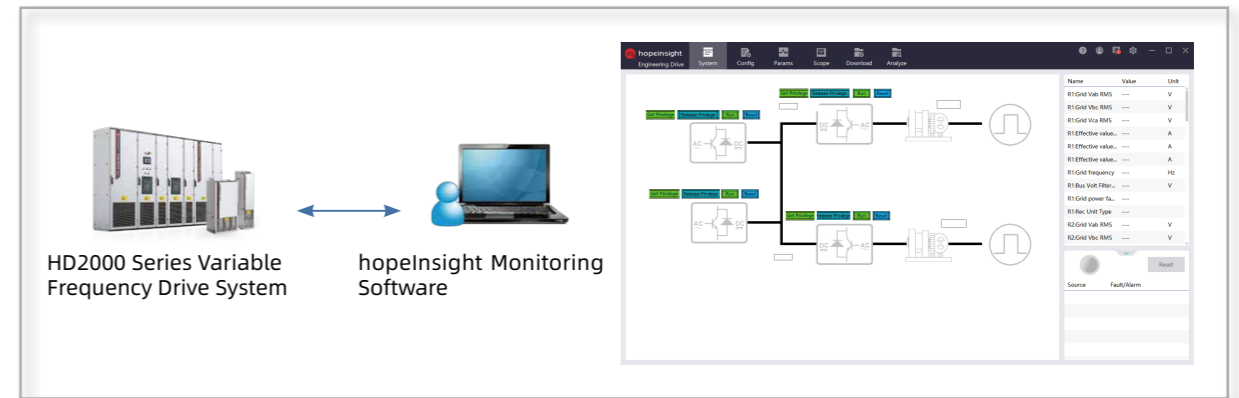

Working Diagram of hopelnsight

Batch Parameter Settings

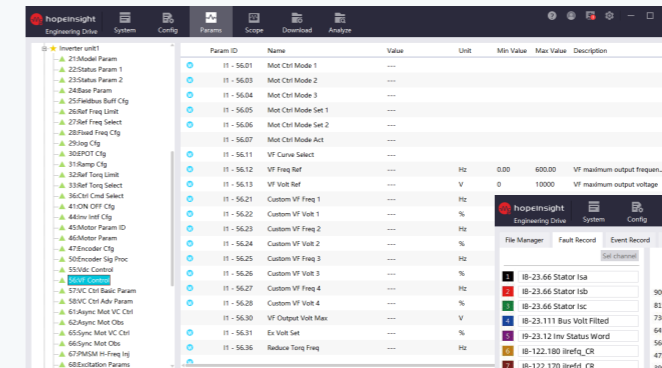

12-Channel High-Speed Software Oscilloscope

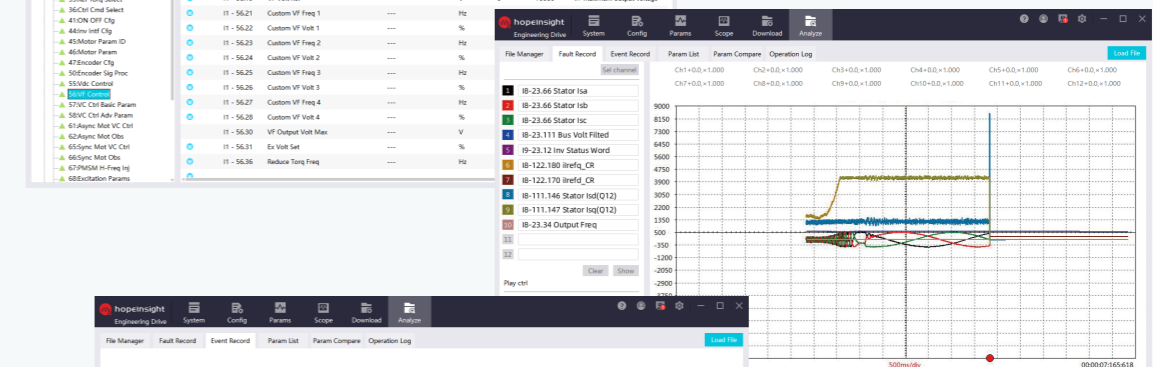

Powerful Fault Wave Recording and Detailed Event Recording

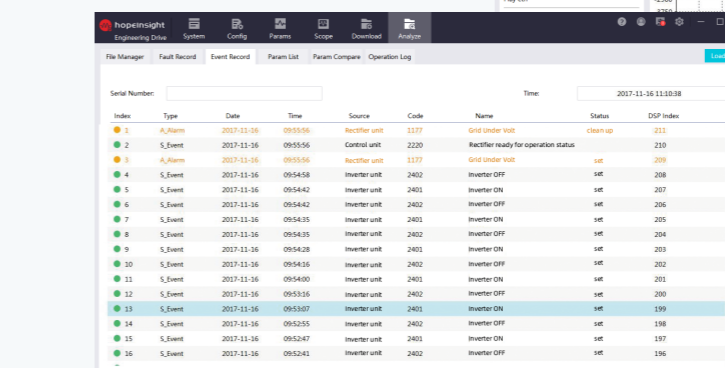

HD2000 Series Low Voltage Engineering Variable Frequency Drive System

Performance Advantages

Four-Quadrant Technology

Key Technical Points

- Smart rectification feedback
- Controllable PWM rectification

Technical Competitiveness

- Smart rectification feedback
 - Four-quadrant operation ensuring rapid feedback and response
 - Simple and reliable trigger mode
- PWM Controllable Rectification
 - Low-harmonic grid current and high power factor
 - Active damping hysteresis control technology for independent control of positive and negative sequence current, enhancing adaptability to unbalanced or weak grids (harmonics, distortions)
 - Controllable DC bus voltage for higher grid adaptability

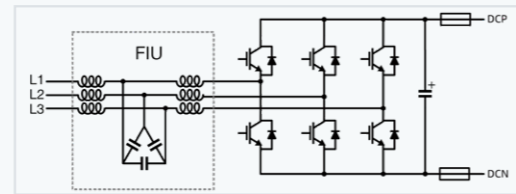
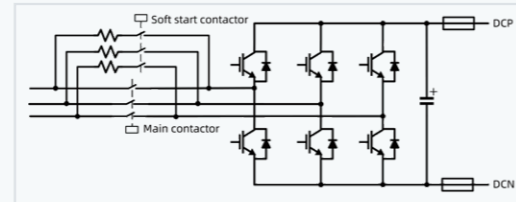

High Torque Response

Key Technical Points

- Current response time of nearly 2 ms when added a rated torque under torque control mode

Technical Competitiveness

- Highly decoupled excitation current and torque current ensuring outstanding dynamic performance (strong load capacity and a wide speed control range)

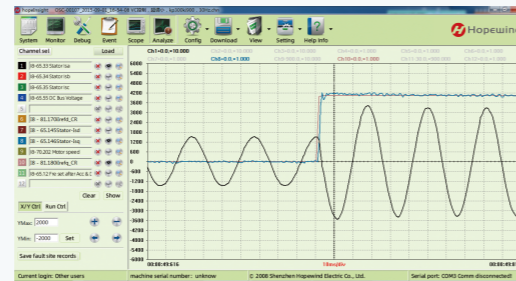

Flux Observation and Speed Estimation

Key Technical Points

- Full-order closed-loop flux observer
 - Auto-tuning to identify motor speed and stator resistance based on estimation error of stator current and estimated value of rotor magnetic flux
 - Overcoming errors caused by speed estimation under OLVC and integral drift, reducing sensitivity to motor parameters

Technical Competitiveness

- Accurate flux observation and speed estimation model, ensuring start torque of 150% at 0.5Hz and hovering at zero speed under OLVC mode

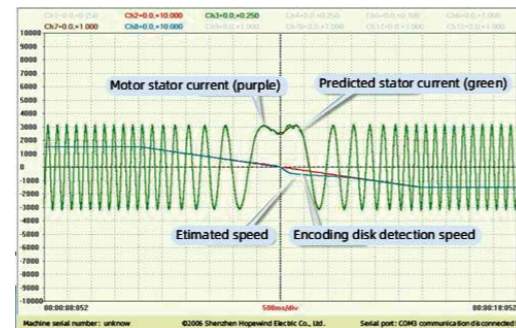

Multi-Axis Control

Key Technical Points

- HCU20 supporting vector and V/F control, capable of simultaneously controlling 3 vector or 8 V/F axes

Technical Competitiveness

- Applicable to multi-axis control in large and complex drive systems

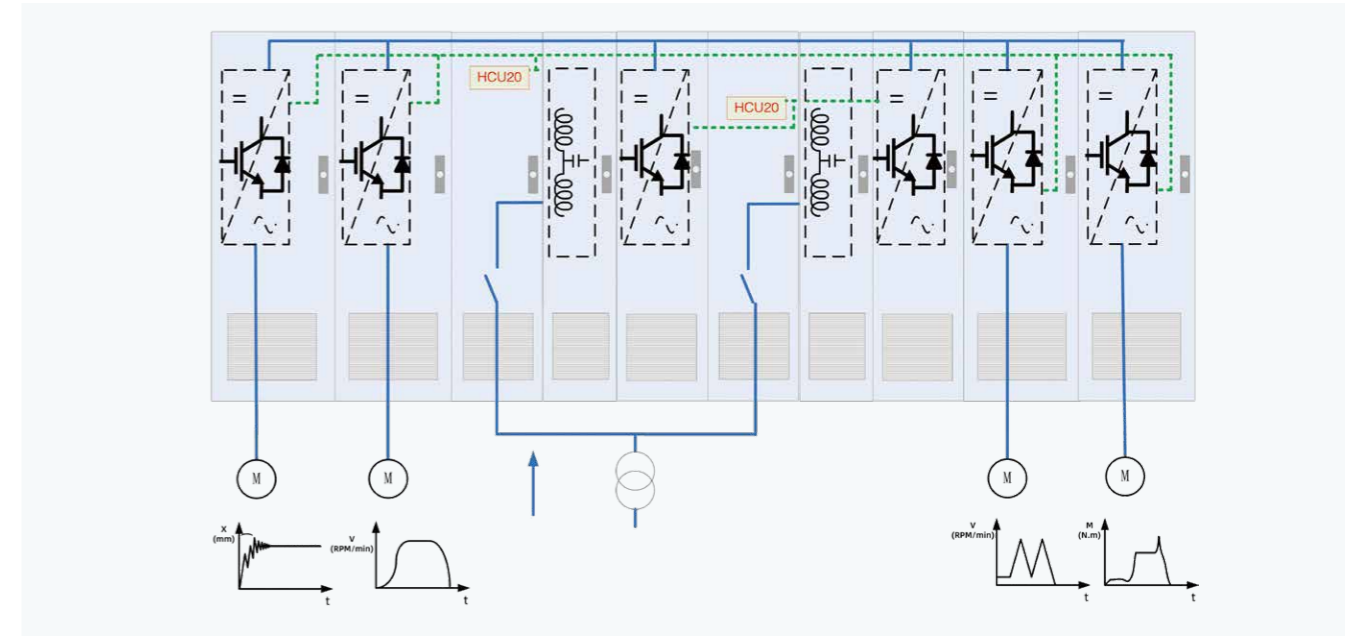

Hovering at Zero Speed

Key Technical Points

- Speed detection at extremely low speed and high torque control at zero speed

Technical Competitiveness

- Precise, reliable, safe and stable zero speed hovering thanks to high-precision speed detection at extremely low speed through FPGA and zero speed hovering control

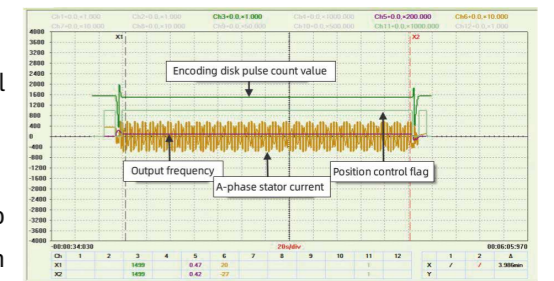

Rapid Frequency-Superposed Braking

Key Technical Points

- Rapid frequency-superposed braking by superposing controllable high-frequency components on output voltage for the motor to generate reverse resistive torque

Technical Competitiveness

- Effectively reducing deceleration time of loaded motors, which meets requirements of special processes

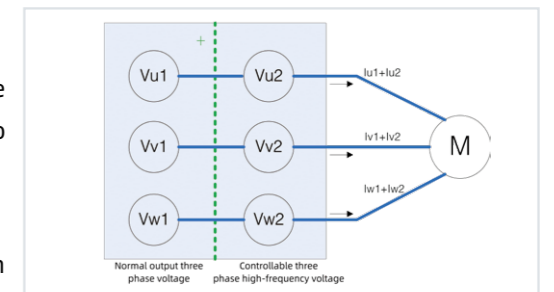

HD2000 Series Low Voltage Engineering Variable Frequency Drive System

Performance Advantages

Direct Parallel Technology

Key Technical Points

- When units are connected in parallel, discrete differences in the drive system or power hardware can result in unbalanced load currents between units. The control system synchronization and parallel current-sharing technology can adjust the output current of each unit in real time to achieve balance control of load currents.

Technical Competitiveness

- Supporting system derated operation in face of unit faults
- Centralized control but decentralized execution system, connected through fiber optics, more conducive to direct parallel connection of units
- Parallel current-sharing technology supporting direct parallel connection of multiple rectifier and inverter units with nanosecond (ns) level synchronization

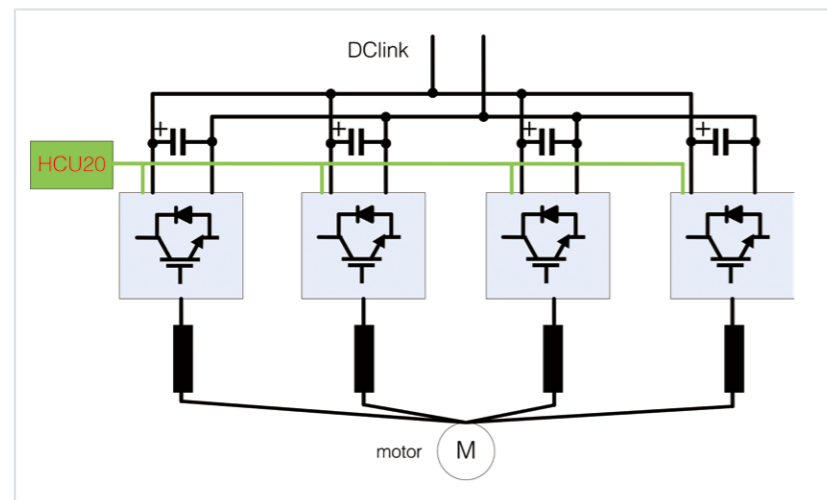

Multi-Motor Synchronization and Load Balance Control

Key Technical Points

- Multiple motors drive the same load, synchronized or proportionally synchronized through bearings, gears, chains, belts, etc. Flexible parameter interconnection helps easily achieve master-slave drive control, static load balance with zero difference, dynamic load balance at millisecond (ms) level, and free switching between master and slave control modes for special applications.

Technical Competitiveness

- Separated multi-axis controllers and power modules, connected through high-speed fiber optic communication, facilitating synchronous control
- Anti-torsional vibration, anti-slip, precise speed synchronization, and load balance control
- Droop control to achieve automatic speed adjustment and load balance without encoder

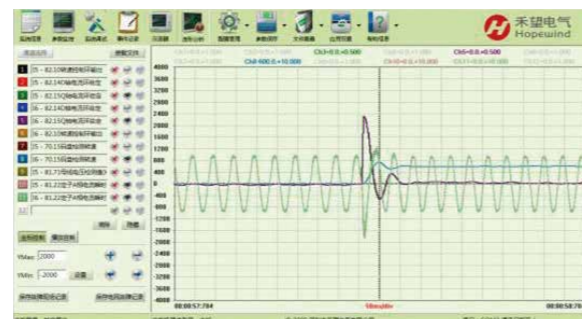

CLVC and OLVC Automatic Online Switching

Key Technical Points

- During CLVC operation, the motor speed is monitored in real time through an accurate motor model. The system can automatically switch to OLVC mode online when an encoder fault occurs and switch back to CLVC mode when it becomes normal.

Technical Competitiveness

- Reducing unnecessary losses caused by encoder fault and abnormal shutdown, meeting the requirements of special applications. Coordinated with the braking control function in lifting scenarios, improving the operation safety of overhead travelling cranes
- Smooth switching process without any current impacts or disturbances

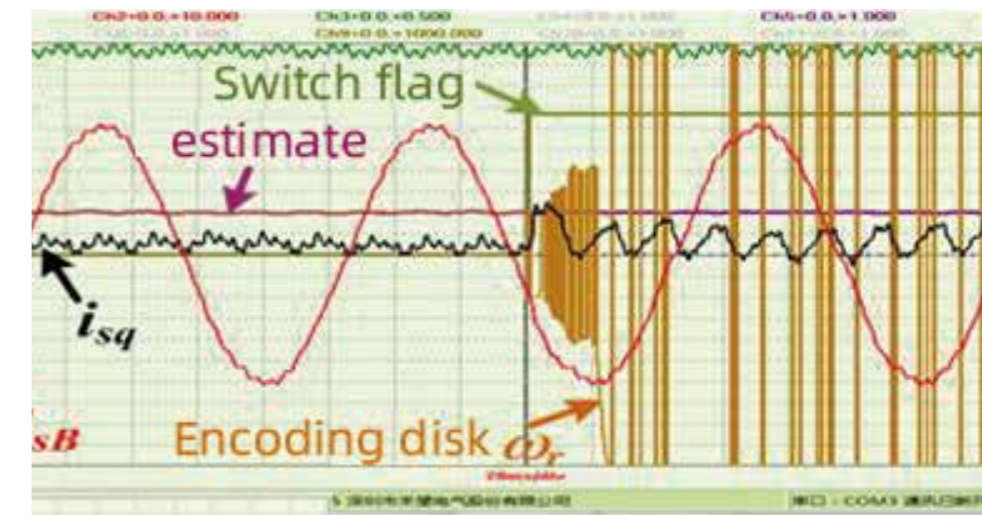

Reliability Assurance

Research and Development:

- Control algorithm simulation platform
- Advanced simulation and verification platform
- Comprehensive motor testing platform
- Finite element thermal, magnetic field, and force simulation platform
- Industry-leading high-power drive product development platform





Standardized Production and Factory Testing:

- Automatic control of testing process
- Traceable life cycle
- 100% Rated voltage full power aging test for all products before leaving the factory
- Industry-leading dedicated testing platform to meet full load testing requirements

HD2000 Series Low Voltage Engineering Variable Frequency Drive System

HD2000 Series Product Classifications

HD2000 Series Low Voltage Engineering Variable Frequency Drive System							
Suitable for Complex Single-Drive/Multi-Drive Modular Drive System							
Cooling method	AC-DC-AC Variable Frequency Unit (Chassis Type)	Multiple AC-DC Rectifier Units and DC/AC Inverters, Suitable for Multi-Drive Applications					
	Basic rectifier type	Basic rectifier unit	Smart rectifier unit	LCL filter interface unit + PWM rectifier unit	Motor drive unit		Standard unit cabinet/whole machine (W*H*D) (mm)
Air-cooled models	5.5~560kW	90~1500kW	7.5~1600kW	11~1600kW	5.5~1400kW	5.5~160kW	
Liquid-cooled models	/	560~2500kW	200~2000kW	235~3400kW	160~2800kW	/	400*2200*650/450*2200*650/600*2200*650/750*2200*650
							
Air-cooled models				Liquid-cooled models		Liquid-cooled models	

Note: HD2000 cabinets or the whole machine can be customized according to customer requirements.

Application Cases



Industry: Metallurgy
Load: High speed wire rod/bar main mill, reducing sizing mill, cold rolling mill, roller bed, straightener, pickling line
Characteristics: Strong overloading capability, high precision, high dynamic response, low speed reduction equivalent



Industry: Port lifting
Load: Quay crane, grab bucket
Characteristics: Potential energy load, constant torque startup, frequent startup, zero-speed suspension



Industry: Oil drilling
Load: Winch, turnplate, mud pump, auto driller, top drive
Characteristics: Multi-axis drive, multi-motor synchronous control, high reliability



Industry: Test benches
Load: Synchronous motor, asynchronous motor
Characteristics: Parallel operation, high power, frequency superposition



Industry: Mining machinery
Load: Excavator, dump truck, mine hoist, conveyor
Characteristics: Multi-axis drive, low-frequency high torque, multi-motor synchronous control, energy regeneration



Industry: Distributed renewable energy generation
Load: Wind turbine, waste heat generator, tidal power generator
Characteristics: Low grid harmonic current, MPPT, customized algorithm

Technical Specifications of HD2000 Series Products

Basic Rectifier	Input voltage	4: 380V ~ 480V, 6: 500V ~ 690V
	Input frequency	(50Hz/60Hz) ±6%
	Output voltage	Input voltage * 1.32 (Under full-load condition)
	Overload capacity	Relative overload at 150% of rated current for 60 seconds, maximum current (Imax), DC overload for 5 seconds
	Operating efficiency	≥99% Efficiency
	Protection functions	Protection functions: Overheating protection, soft-start protection, interlock protection, and more.
Intelligent rectifier	Input voltage	4: 380V ~ 480V, 6: 500V ~ 690V
	Input frequency	47 ~ 63Hz
	Output voltage	Input voltage * 1.3 (Under full-load condition)
	Overload capacity	Relative overload at 150% of rated current for 60 seconds, Maximum current (Imax), DC overload for 5 seconds
	Operating efficiency	≥98.5% Efficiency
	Protection functions	Protection functions: Overheating protection, Overcurrent protection, IGBT pass-through protection, and more
PWM rectifier	Input voltage	4: 380V~480V, 6: 500V~690V, 9: 1140V, A: 1380V
	Input frequency	47 ~ 63Hz
	Output voltage	Input voltage * 1.5 (Under rated conditions)
	Overload capacity	Relative overload at 150% of rated current for 60 seconds, Maximum current (Imax), DC overload for 5 seconds
	Operating efficiency	≥98% Efficiency (Including LCL filter unit)
	Power factor	Adjustable (Factory setting at 1)
Inversion	Protection functions	Protection functions: Overheating protection, Overcurrent protection, Overload protection, IGBT pass-through protection, and more.
	Rated Input voltage	4: 410Vdc ~ 780Vdc, 6: 550Vdc ~ 1100Vdc, 9: 1488Vdc ~ 2200Vdc, A: 1488Vdc~2200Vdc
	Output voltage	0 ~ Rectifier AC input voltage
	Output frequency	0 ~ 500Hz
	Speed range	V/F: 1:50 OLVC: 1:200 CLVC: 1:1000
	Speed stability	OLVC: 0.2% CLVC: 0.01%
	Speed fluctuation	OLVC: 0.2% CLVC: 0.1%
	Starting torque	OLVC: 150%(0.5Hz) CLVC: 200%(0Hz)
	Torque control	V/F: Unsupported OLVC: Supported CLVC: supported
	Torque accuracy	OLVC: 5% CLVC: 5%
	Torque response time	OLVC: 5ms CLVC: 5ms
	Speed response time	OLVC: 100ms CLVC: 100ms
	Dynamic speed drop equivalent	OLVC: 0.5%*s CLVC: 0.3%*s
Environmental conditions	Temperature	-15°C ~ +40°C Without derating, +40°C ~ +55°C derating applies
	Humidity	5% ~ 95% Non-condensing
	Altitude	≤4000m, Derating applies from 2000m to 4000m
Mechanical data	Anti-vibration performance	Complies with IEC 60721-3-3:2002
	Protection level	IP00 / IP20 / IP40
	Safety level	Complies with UL 508C-2004
	Cooling method	Air-cooled, Water-cooled

HCU20 Control Unit

Product Overview



The HCU20 serves as the core component of the inverter, primarily providing a hardware platform for the control software and offering both internal and external interfaces, including I/O and communication interfaces.

Model Description

HCU20 - DP - 1 - 6

Control unit series name:

HCU20

Fieldbus type:

CA: CANopen CN: ControlNet DN: DeviceNet
 DP: Profibus MR: Modbus RTU PN: Profinet IO
 TP: Modbus TCP/IP EC: EtherCAT
 EN: EtherNet/IP NA: Not applicable

Optional interface board type:

1: AIO (Analog input/output)

Number of fiber interfaces:

6: Six fiber interfaces

Main Functions

No.	Function	Description
1	Communication	Communication with rectifier unit/motor drive unit
2		Communication with host inverter
3		Communication with PC
4		Communication with control panel
5		Communication With expansion module
6	Digital interface	Input/Output of digital signal
7	Analog interface	Input/Output of analog signal
8	Control	Control of rectifier/Inverter/Interface unit

Structural Dimension

Max. Dimensions (W*H*D) (mm)	56*280*174
Weight	≤ 2 kg
Protection Rating	IP20

Structure Size

Item	Quantity	Specifications	Note
Digital input	10	Electrical isolation: 5V Input voltage: 0V ~ 30V Input current (Typ): 10mA/24VDC Input high Level: 15V ~ 30V Input low Level: 0V ~ 5V Input delay (Typ): 300µs	X1
Digital input/output	8	Used as DI: Channel 2 supports fast pulse input Input voltage: 0V ~ 30V Input current (Typ): 10mA@24VDC Input high level: 15V ~ 30V Input low level: 0V ~ 5V Input delay (Typ): 5µs Input frequency (fast): 1Hz ~ 100kHz Used as DO: Channel 1 is a fast pulse output interface. Output high level: 22V~24V Load capacity: 500mA (The total Load current of all DOs cannot exceed 2A.) Output delay (Typ): 100µs (Normal), 5µs (Fast) Output frequency (Fast): 0.1kHz~100kHz	X2 Input/output configured via software
Relay	3	Contact type: Form C Contact load capacity: 2A Contact voltage: 250VAC/30VDC Mechanical life: 100,000 times	X12 Supported when interface board type is 1
AO	2	Voltage output: Output voltage: -12.5V ~ +12.5V Load capacity: 10mA Resolution: 12bit Accuracy: 1% Other: Overcurrent protection (20mA) Current type: Output current: -25mA~25mA Load capacity: 500Ω Resolution: 12-bit Accuracy: 1%	X11 Supported when interface board type is 1 Input/output type configured via software
AI	2	Voltage input: Input voltage: -12.5V ~ +12.5V Input impedance: 14kΩ Resolution: 12bit Accuracy: 1% Current input: Input current: -25mA~25mA Input impedance: 100Ω Resolution: 12bit Accuracy: 1% Other: Overcurrent protection (20mA)	
Voltage reference output	1	Output voltage: -10V & +10V Load capacity: 10mA Accuracy: 1% Other: Overcurrent protection (20mA)	Supported when interface board Type is 1
Fieldbus communication	1	External interface: Profibus-DP, CANopen, Profinet IO, Modbus RTU, Modbus TCP, EtherCAT, EtherNet/IP, ControlNet, and DeviceNet (built-in, one type supported at a time) External baud rate: Selected communication protocol dependent Internal interface: SCI Internal baud rate: < 625kbps	X3 Customizable communication protocols supported via optional modules
PPLink optical fiber interface	6~12	Interface type: PPLink Communication medium: Plastic optical fiber Baud rate: 10Mbps Communication distance: 50m	X21~X26 ①Used for master-slave control Direct connection: One master + one slave Connection through optical fiber module: One master + multiple slaves ②Used for connecting power module/ expansion module
Keyboard interface	1	External keyboard connected through RS485/RS422 interface Interface type: RS485/RS422 Baud rate: < 250kbps Communication distance: 50m	X28 RS485: Used for connection with keyboard RS422: Used for connection to WiFi for keyboard or communication with the background (Ethernet-to-serial converter needed)
Background commissioning interface	1	External interface type: Ethernet External baud rate: 10/100Mbps Internal interface type: SCI Internal baud rate: 9600bps ~ 921600bps (Dynamic switching) Communication distance: 50m	X27
Input power supply	1	Input voltage: 24VDC (-15% ~ +20%) Input current: < 1A Safety requirements: SELV	X4
SD card upgrade interface	1	Standard SD card supported Capacity: Up to 4GB Speed: Class 10	X29
CAN master-slave /485 communication	2	Interface type: CAN/485 Baud rate: < 1Mbps/16Mbps Communication distance: 40m/1200m (at 1M) Default matching resistance: 240Ω (Switchable to 360Ω via background)	X30, X31 Isolation of CAN master-slave and 485 communication (Which can be used simultaneously)

Note: Interface modules and encoder modules can be sold together with the control unit.

Operator Panel

Product Overview

The HIC200-OP-10 is an intelligent operator panel independently developed by Hopewind Electric for high-performance drive products. It features a multi-function and user-friendly interface which is easy to use. It is suitable for parameter monitoring and changing for high-performance single-/multi-drive systems.



Encoder Module

The encoder module is primarily used for detecting motor speed and temperature.

The HD2000 supports various models of encoder modules, which are used in conjunction with corresponding unit products. Their system configuration is determined by the application scenarios.

Selection

Application Range	Chassis type Motor Drive Unit		Compact Type Motor Drive Unit
Encoder model	HIC200-EIM10	HIC200-EIM30	HVPG-ABZ
Resolver	Supported	-	-
Incremental encoder TTL/HTL	-	Supported	Supported
Absolute value encoder	-	Supported	-
Temperature signal converter	Supported	Supported	-
Max. dimensions (W*H*D) (mm)	34*188*118 (Wall-mounted installation)		62*77*32.1 (Plug-in installation)

HD2000 Unit Selection (Air-Cooled)

The units of the HD2000 series air-cooled inverter include single-drive AC-DC-AC variable frequency units, multi-drive AC-DC rectifier units and DC-AC motor drive units.

These units need to be equipped with corresponding power distribution protection devices, and users can only use them normally after secondary integration.

Frame Type	Weight (kg)	Frame Type	Weight (kg)	Frame Type	Weight (kg)
3U	6.7	F4	9	GU	168
4U	9	F5	29.5	HU	289
5U	29.5	F6	53	IU	362
6U	53	F7	75	JU	452
7U	37	DU	100	KU	582
F3	6.7	EU	187	LU	117

Note: The weight provided above refers to the net weight of the unit. Please refer to the actual product for specific parameters.

Two-Quadrant Variable Frequency Unit (VFU)

Model	Rated		Light Load		Heavy Load		Frame Type	Dimensions W*H*D (mm)
	Current (A)	Motor Power (kW)	Current (A)	Motor Power (kW)	Current (A)	Motor Power (kW)		
Three-Phase AC 400V (380V~480V)								
HD2000-33B00174B	17	7.5	16	7.5	15	5.5	F3	132*393*258
HD2000-33B00254B	25	11	24	11	22	7.5		
HD2000-33B00324B	32	15	31	15	28	11		
HD2000-33B00384B	38	18.5	37	18.5	34	15	F4	132*441*298
HD2000-33B00464B	46	22	45	22	41	18.5		
HD2000-33B00604B	60	30	58	30	53	22	F5	240*501*334
HD2000-33B00754(B)	75	37	73	37	67	30		
HD2000-33B00914(B)	91	45	88	45	81	37	F6	295*593*386
HD2000-33B01254(B)	125	55	121	55	111	45		
HD2000-33B01564(B)	156	75	151	75	139	55	F7	340*724*405
HD2000-33B01804(B)	180	90	175	90	160	75		
HD2000-33B02144(B)	214	110	208	110	191	90	GU	325*1530*543
HD2000-33B02654(B)	265	132	257	132	236	110		
HD2000-33B03124(B)	312	160	303	160	278	132	HU	502*1487*545
HD2000-33B03804(B)	380	200	369	200	338	160		
HD2000-33B04904(B)	490	250	475	250	436	200	HU	502*1487*545
HD2000-33B06054(B)	605	315	587	315	538	250		
HD2000-33B07454(B)	745	400	723	400	663	315	HU	502*1487*545
HD2000-33B08404(B)	840	450	815	450	748	400		
Three-Phase AC 690V (500V~690V)								
HD2000-33B00636(B)	63	55	61	55	56	45	F6	295*593*386
HD2000-33B00866(B)	86	75	83	75	77	55		
HD2000-33B01016(B)	101	90	97	90	89	75		
HD2000-33B01216(B)	121	110	118	110	108	90	F7	340*724*405
HD2000-33B01516(B)	151	132	147	132	135	110		
HD2000-33B01766(B)	176	160	171	160	157	132	GU	325*1530*543
HD2000-33B02156(B)	215	200	209	200	191	160		
HD2000-33B02606(B)	260	250	252	250	231	200	HU	502*1487*545
HD2000-33B03306(B)	330	315	320	315	294	250		
HD2000-33B04106(B)	410	400	398	400	365	315	HU	502*1487*545
HD2000-33B04656(B)	465	450	451	450	414	400		
HD2000-33B05756(B)	575	560	558	560	512	450		

Note:

(1) F3 and F4 frames are equipped with standard brake units by default.

(2) Models ended with "(B)" indicate that they can be equipped with optional brake units after purchase. For example, the product of model HD2000-33B00754B is equipped with built-in brake unit before leaving the factory while the product of model HD2000-33B00754 is not.

HD2000 Unit Selection (Air-Cooled)

Basic Rectifier Unit (BRU): Performs two-quadrant rectification of the grid voltage and does not have energy feedback. It must be combined with a braking unit and braking resistor to consume the braking energy generated in the device. The input side must be equipped with an AC input reactor.

Smart Rectifier Unit (SRU): Performs four-quadrant rectification of the grid voltage and has energy feedback. However, the DC bus voltage is not controllable and is determined by the input grid voltage and load. The input side must be equipped with an AC input reactor.

PWM Rectifier Unit (PRU): Performs four-quadrant PWM rectification of the grid voltage and has energy feedback. The DC bus voltage is adjustable. The input side must be equipped with an LCL filter interface unit (FIU).

Attributes	Basic Rectifier Unit (BRU)	Smart Rectifier Unit (SRU)	PWM Rectifier Unit (PRU)
Energy feedback	No	Yes	Yes
DC bus voltage	Uncontrollable	Uncontrollable	Controllable (Sine wave)
Power factor	Low	Low	High (Factory setting: $\cos\Phi=1$)
Harmonics	High	High	Low

Multi-Drive Basic Rectifier Unit (BRU)

Model	Rated Power (kW)	AC Current		DC Current			Frame Type	Dimensions W*H*D (mm)
		Rated Current I_N (A)	Max. Current I_{max} (A)	Rated Current $I_{N,DC}$ (A)	Basic Load Current $I_{h,DC}$ (A)	Max. Current $I_{max,DC}$ (A)		
Three-Phase AC 400V (380V~480V)								
HD2000-11B01624	90	162	244	193	151	290	DU	310*1260*405
HD2000-11B01984	110	198	298	236	184	354		
HD2000-11B02384	132	238	357	283	221	425		
HD2000-11B02894	160	289	433	343	268	515		
HD2000-11B03614	200	361	541	429	335	644		
HD2000-11B04514	250	451	677	536	418	804		
HD2000-11B07224	400	722	1083	858	669	1287		
HD2000-11B10104	560	1010	1516	1201	937	1802		
HD2000-11B12814	710	1281	1922	1523	1188	2285	EU	310*1640*543
HD2000-10B16244 ⁽¹⁾	900	1624	2436	1931	1506	2896		
Three-Phase AC 690V (500V~690V)								
HD2000-11B00946	90	94	141	112	87	168	DU	310*1260*405
HD2000-11B01156	110	115	173	137	107	205		
HD2000-11B01386	132	138	207	164	128	246		
HD2000-11B01676	160	167	251	199	155	298		
HD2000-11B02096	200	209	314	249	194	373		
HD2000-11B02616	250	261	392	311	243	466		
HD2000-11B03716	355	371	557	441	344	662		
HD2000-11B05866	560	586	879	696	543	1045		
HD2000-11B09416	900	941	1412	1119	873	1679		
HD2000-11B11516	1100	1151	1726	1368	1067	2052		
HD2000-10B15696 ⁽²⁾	1500	1569	2353	1865	1455	2798	EU	310*1640*543

Note:
 (1) The basic rectifier unit of 400V/900kW adopts diode rectification, and external precharging circuit is required.
 (2) The basic rectifier unit of 690V/1500kW (and above) adopts diode rectification, and external precharging circuit is required.

Multi-Drive Smart Rectifier Unit (SRU)

Model	Rated Power (kW)	AC Current		DC Current			Frame Type	Dimensions W*H*D (mm)
		Rated Current I_N (A)	Max. Current I_{max} (A)	Rated Current $I_{N,DC}$ (A)	Basic Load Current $I_{h,DC}$ (A)	Max. Current $I_{max,DC}$ (A)		
Three-Phase AC 400V (380V~480V)								
HD2000-12B00144	7.5	14	21	16	14	24	3U	132*393*258
HD2000-12B00204	11	20	30	24	21	36		
HD2000-12B00274	15	27	41	33	29	49		
HD2000-12B00344	18.5	34	51	40	36	60	4U	132*441*298
HD2000-12B00404	22	40	60	48	42	72		
HD2000-12B00554	30	55	82	65	58	98		
HD2000-12B00674	37	67	101	80	71	120	5U	140*500*335
HD2000-12B00824	45	82	123	98	87	146		
HD2000-12B01004	55	100	150	119	106	179		
HD2000-12B01374	75	137	205	163	145	244	6U	165*592*385
HD2000-12B01654	90	165	246	195	174	293		
HD2000-12B02014	110	201	302	238	212	357		
HD2000-12B02424	132	242	363	287	255	431	7U	175*724*407
HD2000-12B02934	160	293	440	348	310	522		
HD2000-12B03644	200	364	547	433	386	650		
HD2000-12B04564	250	456	683	542	482	813	GU	325*1530*543
HD2000-12B06474	355	647	970	769	685	1154		
HD2000-12B09114	500	911	1367	1083	964	1625		
HD2000-12B11484	630	1148	1722	1365	1215	2048	IU	707*1487*545
HD2000-12B14584	800	1458	2187	1734	1543	2600		
Three-Phase AC 690V (500V~690V)								
HD2000-12B00586	55	58	87	69	61	104	6U	165*592*385
HD2000-12B00796	75	79	119	94	84	141		
HD2000-12B00966	90	96	143	113	101	170		
HD2000-12B01176	110	117	176	139	124	209	7U	175*724*407
HD2000-12B01406	132	140	210	166	148	249		
HD2000-12B01706	160	170	255	202	180	303		
HD2000-12B02116	200	211	317	251	224	377	GU	325*1530*543
HD2000-12B02646	250	264	396	314	280	471		
HD2000-12B03336	315	333	499	396	352	594		
HD2000-12B04756	450	475	713	565	503	848	HU	502*1487*545
HD2000-12B07506	710	750	1125	892	794	1338		
HD2000-12B10576	1000	1057	1585	1256	1118	1884		
HD2000-12B14796	1400	1479	2219	1759	1565	2638	IU	707*1487*545
HD2000-12B16906	1600	1690	2535	2009	1788	3014		

HD2000 Unit Selection (Air-Cooled)

Multi-Drive PWM Rectifier Unit (PRU)

Model	Rated Power (kW)	AC Current		DC Current			Frame Type	Dimensions W*H*D (mm)
		Rated Current I _N (A)	Max. Current I _{max} (A)	Rated Current I _{N,DC} (A)	Basic Load Current I _{h,DC} (A)	Max. Current I _{max,DC} (A)		
Three-Phase AC 400V (380V~480V)								
HD2000-13B00184	11	18	26	20	18	30	3U	132*393*258
HD2000-13B00244	15	24	36	27	24	40		
HD2000-13B00304	18.5	30	45	33	30	50		
HD2000-13B00354	22	35	53	40	35	59		
HD2000-13B00484	30	48	72	54	48	81	4U	132*441*298
HD2000-13B00594	37	59	89	66	59	100		
HD2000-13B00724	45	72	108	81	72	121	5U	140*500*335
HD2000-13B00884	55	88	132	99	88	148		
HD2000-13B01204	75	120	180	135	120	202	6U	165*592*385
HD2000-13B01454	90	145	217	162	144	242		
HD2000-13B01774	110	177	265	198	176	296		
HD2000-13B02134	132	213	320	238	212	357	7U	175*724*407
HD2000-13B02584	160	258	387	288	256	432		
HD2000-13B03454	200	345	518	386	343	579	GU	325*1530*543
HD2000-13B04814	300	481	722	539	480	808		
HD2000-13B06094	380	609	914	683	607	1024	HU	502*1487*545
HD2000-13B07224	450	722	1083	808	719	1212		
HD2000-13B08024	500	802	1203	898	799	1347	IU	707*1487*545
HD2000-13B10104	630	1010	1516	1132	1007	1697		
HD2000-13B12834	800	1283	1925	1437	1279	2156		
HD2000-13B14434	900	1443	2165	1617	1439	2425		
Three-Phase AC 690V (500V~690V)								
HD2000-13B00706	75	70	105	78	70	117	6U	165*592*385
HD2000-13B00856	90	85	126	94	83	141		
HD2000-13B01036	110	103	153	115	102	172		
HD2000-13B01246	132	124	186	138	123	207	7U	175*724*407
HD2000-13B01506	160	150	225	167	149	251		
HD2000-13B01886	200	188	282	209	186	314	GU	325*1530*543
HD2000-13B02326	250	232	349	260	232	390		
HD2000-13B02936	315	293	439	328	292	492	HU	502*1487*545
HD2000-13B03726	400	372	558	417	371	625		
HD2000-13B04656	500	465	697	521	463	781	IU	707*1487*545
HD2000-13B05756	560	575	862	644	573	966		
HD2000-13B07446	800	744	1116	833	741	1250		
HD2000-13B10236	1100	1023	1534	1145	1019	1718		
HD2000-13B13026	1400	1302	1952	1458	1297	2187		
HD2000-13B14886	1600	1488	2231	1667	1484	2501		

Multi-Drive LCL Filter Interface Unit (FIU)

Model	AC Current		Matched Rectifier Unit Model	Frame Type	Dimensions W*H*D (mm)
	Rated Current I _N (A)	Max. Current I _{max} (A)			
Three-Phase AC 400V (380V~480V)					
HD2000-15B02134	213	318	HD2000-13B02134	FU	325*1400*405
HD2000-15B02584	258	386	HD2000-13B02584		
HD2000-15B03454	345	518	HD2000-13B03454	GU	325*1530*543
HD2000-15B04814	481	722	HD2000-13B04814		
HD2000-14B06094 ⁽¹⁾	609	914	HD2000-13B06094	JU	505*1575*544
HD2000-14B07224 ⁽¹⁾	722	1083	HD2000-13B07224		
HD2000-14B08024 ⁽¹⁾	802	1203	HD2000-13B08024	KU	505*1750*544
HD2000-14B10104 ⁽¹⁾	1010	1515	HD2000-13B10104		
HD2000-14B12834 ⁽¹⁾	1283	1925	HD2000-13B12834		
HD2000-14B14434 ⁽¹⁾	1443	2165	HD2000-13B14434		
Three-Phase AC 690V (500V~690V)					
HD2000-15B00706	70	105	HD2000-13B00706	-	-
HD2000-15B00856	85	126	HD2000-13B00856		
HD2000-15B01036	103	153	HD2000-13B01036	FU	325*1400*405
HD2000-15B01246	124	184	HD2000-13B01246		
HD2000-15B01506	150	223	HD2000-13B01506	GU	325*1530*543
HD2000-15B01886	188	279	HD2000-13B01886		
HD2000-15B02326	232	349	HD2000-13B02326	JU	505*1575*544
HD2000-15B02936	293	439	HD2000-13B02936		
HD2000-15B03726	372	558	HD2000-13B03726	KU	505*1750*544
HD2000-14B04656 ⁽¹⁾	465	697	HD2000-13B04656		
HD2000-14B05756 ⁽¹⁾	575	862	HD2000-13B05756		
HD2000-14B07446 ⁽¹⁾	744	1116	HD2000-13B07446		
HD2000-14B10236 ⁽¹⁾	1023	1534	HD2000-13B10236		
HD2000-14B13026 ⁽¹⁾	1302	1952	HD2000-13B13026		
HD2000-14B14886 ⁽¹⁾	1488	2231	HD2000-13B14886		

Note: An external bypass contactor shall be equipped for LCL filter interface units marked with superscript of (1) on the model.

HD2000 Unit Selection (Air-Cooled)

The chassis type motor drive unit is controlled by an independent HCU20 control unit. Therefore, the HCU20 control unit and HIC200-OP-10 operation panel should be also selected when purchased.

The compact type motor drive unit is controlled by an integrated controller. The controller and keypad have already been integrated in the unit before leaving the factory, no need to be purchased separately.

Chassis Type Motor Drive Unit (MDU)

Model	Rated		Light Load		Heavy Load		Frame Type	Dimensions W*H*D (mm)
	Current (A)	Motor Power (kW)	Current (A)	Motor Power (kW)	Current (A)	Motor Power (kW)		
Three-Phase AC 400V (380V~480V), DC Circuit Voltage 510V~720V								
HD2000-16B00174B	17	7.5	16	7.5	15	5.5	3U	132*393*258
HD2000-16B00254B	25	11	24	11	22	7.5		
HD2000-16B00324B	32	15	31	15	28	11		
HD2000-16B00384B	38	18.5	37	18.5	34	15	4U	132*441*298
HD2000-16B00464B	46	22	45	22	41	18.5		
HD2000-16B00604B	60	30	58	30	53	22		
HD2000-16B00754(B)	75	37	73	37	67	30	5U	140*500*335
HD2000-16B00914(B)	91	45	88	45	81	37		
HD2000-16B01254(B)	125	55	121	55	111	45	6U	165*592*385
HD2000-16B01564(B)	156	75	151	75	139	55		
HD2000-16B01804(B)	180	90	175	90	160	75		
HD2000-16B02144	214	110	208	110	191	90	7U	175*724*407
HD2000-16B02654	265	132	257	132	236	110		
HD2000-16B03124	312	160	303	160	278	132		
HD2000-16B03804	380	200	369	200	338	160	GU	325*1530*543
HD2000-16B04904	490	250	475	250	436	200		
HD2000-16B06054	605	315	587	315	538	250	HU	502*1487*545
HD2000-16B07454	745	400	723	400	663	315		
HD2000-16B08404	840	450	815	450	748	400		
HD2000-16B09854	985	560	955	560	877	450	IU	707*1487*545
HD2000-16B12604	1260	710	1222	710	1121	560		
HD2000-16B14054	1405	800	1363	800	1250	710		
Three-Phase AC 690V (500V~690V), DC Circuit Voltage 675V~1050V								
HD2000-16B00636(B)	63	55	61	55	56	45	6U	165*592*385
HD2000-16B00866(B)	86	75	83	75	77	55		
HD2000-16B01016(B)	101	90	97	90	89	75		
HD2000-16B01216	121	110	117	110	108	90	7U	175*724*407
HD2000-16B01516	151	132	147	132	134	110		
HD2000-16B01766	176	160	171	160	157	132		
HD2000-16B02156	215	200	209	200	191	160	GU	325*1530*543
HD2000-16B02606	260	250	252	250	231	200		
HD2000-16B03306	330	315	320	315	294	250		
HD2000-16B04106	410	400	398	400	365	315	HU	502*1487*545
HD2000-16B04656	465	450	451	450	414	400		
HD2000-16B05756	575	560	558	560	512	450		
HD2000-16B07356	735	710	713	710	654	630	IU	707*1487*545
HD2000-16B08106	810	800	786	800	721	710		
HD2000-16B09106	910	900	883	900	810	800		
HD2000-16B10256	1025	1000	994	1000	912	900	IU	707*1487*545
HD2000-16B12706	1270	1200	1232	1200	1130	1000		
HD2000-16B14826	1482	1400	1438	1400	1319	1200		

Motor drive units of 400V/30kW (or below) are equipped with standard brake units by default. Models ended with "(B)" indicate that they can be equipped with optional brake units after purchase. For other models, the appropriate capacity and quantity of brake units should be selected separately based on actual needs.

Compact Type Motor Drive Unit (MDU)

Model	Rated		Light Load		Heavy Load		Frame Type	Dimensions W*H*D (mm)
	Current (A)	Motor Power (kW)	Current (A)	Motor Power (kW)	Current (A)	Motor Power (kW)		
Three-Phase AC 400V (380V~480V), DC Circuit Voltage 510V~720V								
HD2000-16B00174B-S	17	7.5	16	7.5	15	5.5	3U	132*393*258
HD2000-16B00254B-S	25	11	24	11	22	7.5		
HD2000-16B00324B-S	32	15	31	15	28	11		
HD2000-16B00384B-S	38	18.5	37	18.5	34	15	4U	132*441*298
HD2000-16B00464B-S	46	22	45	22	41	18.5		
HD2000-16B00604B-S	60	30	58	30	53	22		
HD2000-16B00754-S	75	37	73	37	67	30	5U	140*500*335
HD2000-16B00914-S	91	45	88	45	81	37		
HD2000-16B01254-S	125	55	121	55	111	45	6U	165*592*385
HD2000-16B01564-S	156	75	151	75	139	55		
HD2000-16B01804-S	180	90	175	90	160	75		
HD2000-16B02104-S	210	110	204	110	187	90	7U	175*724*407
HD2000-16B02604-S	260	132	252	132	231	110		
HD2000-16B03104-S	310	160	301	160	276	132		
Three-Phase AC 690V (500V~690V), DC Circuit Voltage 675~1050V								
HD2000-16B00636-S	63	55	61	55	56	45	6U	165*592*385
HD2000-16B00866-S	86	75	83	75	77	55		
HD2000-16B01016-S	101	90	97	90	89	75		
HD2000-16B01206-S	120	110	116	110	107	90	7U	175*724*407
HD2000-16B01506-S	150	132	146	132	134	110		
HD2000-16B01756-S	175	160	170	160	156	132		

Note: Models ended with "B" indicate that they are equipped with standard brake units. Other models can be equipped with optional brake units by adding "B" at the end of the model according to actual needs.

Power Brake Unit - Centralized

Model	Rated Power P _{DB} (kW)	Peak Power P ₁₅ (kW)	Min. Braking Resistance (Ω)	Braking Start Voltage (V)	Braking End Voltage (V)	Frame Type	Dimensions W*H*D (mm)
AC Input Voltage (380V~480V)							
HD2000-18B06504	200 (480V) 151 (380V)	730 (480V) 552 (380V)	0.82	774 (480V) 673 (380V)	735 (480V) 639 (380V)	LU	310*1300*543
HD2000-18B12004	370 (480V) 280 (380V)	1380 (480V) 1043 (380V)	0.43	774 (480V) 673 (380V)	735 (480V) 639 (380V)		
AC Input Voltage (500V~600V)							
HD2000-18B05806	220 (600V) 166 (500V)	830 (600V) 628 (500V)	1.13	967 (600V) 841 (500V)	919 (600V) 799 (500V)	LU	310*1300*543
HD2000-18B11006	420 (600V) 318 (500V)	1580 (600V) 1195 (500V)	0.59	967 (600V) 841 (500V)	919 (600V) 799 (500V)		
AC Input Voltage (660V~690V)							
HD2000-18B05206	240 (690V) 205 (660V)	920 (690V) 785 (660V)	1.46	1158 (690V) 1070 (660V)	1100 (690V) 1017 (660V)	LU	310*1300*543
HD2000-18B10006	460 (690V) 393 (660V)	1700 (690V) 1451 (660V)	0.79	1158 (690V) 1070 (660V)	1100 (690V) 1017 (660V)		

Note: Greater braking power can be obtained through paralleling braking units.

Power Brake Unit - Distributed

Model	Rated Power P _{DB} (kW)	Peak Power P ₁₅ (kW)	Min. Braking Resistance (Ω)	Braking Start Voltage (V)	Braking End Voltage (V)	Frame Type	Dimensions W*H*D (mm)
AC Input Voltage (380V~480V)							
HD2000-19B01614	25 (480V) 19 (380V)	125 (480V) 95 (380V)	4.8	774 (480V) 673 (380V)	735 (480V) 639 (380V)	BU	107*130*330
HD2000-19B03234	50 (480V) 38 (380V)	250 (480V) 189 (380V)	2.4	774 (480V) 673 (380V)	735 (480V) 639 (380V)		
AC Input Voltage (500V~600V)							
HD2000-19B01296	25 (600V) 19 (500V)	125 (600V) 95 (500V)	7.5	967 (600V) 841 (500V)	919 (600V) 799 (500V)	BU	107*130*330
HD2000-19B02596	50 (600V) 38 (500V)	250 (600V) 189 (500V)	3.7	967 (600V) 841 (500V)	919 (600V) 799 (500V)		
AC Input Voltage (660V~690V)							
HD2000-19B01086	25 (690V) 21 (660V)	125 (690V) 107 (660V)	10.7	1158 (690V) 1070 (660V)	1100 (690V) 1017 (660V)	BU	107*130*330
HD2000-19B02166	50 (690V) 43 (660V)	250 (690V) 213 (660V)	5.4	1158 (690V) 1070 (660V)	1100 (690V) 1017 (660V)		

Note: Greater braking power can be obtained through paralleling braking units. A maximum of 3 distributed units can be paralleled.

HD2000 Cabinet Selection (Air-Cooled)

Multi-Drive Incoming Control Cabinet (ICC) - Used for SRC

Model	Rated Current (A)	Frame Type	Dimensions W*H*D (mm)	Corresponding SRC
Three-Phase AC 400V (380V~480V)				
HD2000-30D02504+L200	250	AC	400*2200*650	HD2000-12D01654
HD2000-30D02504+L201	250			HD2000-12D02014
HD2000-30D02504+L202	250			HD2000-12D02424
HD2000-30D04004+L203	400			HD2000-12D02934
HD2000-30D04004+L204	400			HD2000-12D03644
HD2000-30D06304+L205	630	BC	600*2200*650	HD2000-12D04564
HD2000-30D12504+L206	1250			HD2000-12D06474
HD2000-30D12504+L207	1250			HD2000-12D09114
HD2000-30D12504+L208	1250			HD2000-12D11484
HD2000-30D16004+L209	1600			HD2000-12D14584
Three-Phase AC 690V (500V~690V)				
HD2000-30D01606+L210	160	AC	400*2200*650	HD2000-12D00966
HD2000-30D01606+L211	160			HD2000-12D01176
HD2000-30D01606+L212	160			HD2000-12D01406
HD2000-30D02506+L213	250			HD2000-12D01706
HD2000-30D02506+L214	250			HD2000-12D02116
HD2000-30D04006+L215	400	BC	600*2200*650	HD2000-12D02646
HD2000-30D04006+L216	400			HD2000-12D03336
HD2000-30D06306+L217	630			HD2000-12D04756
HD2000-30D12506+L218	1250			HD2000-12D07506
HD2000-30D12506+L219	1250			HD2000-12D10576
HD2000-30D16006+L220	1600	BC	600*2200*650	HD2000-12D14796
HD2000-30D20006+L221	2000			HD2000-12D16906

Multi-Drive Incoming Control Cabinet (ICC) - Used for PRC

Model	Rated Current (A)	Frame Type	Dimensions W*H*D (mm)	Corresponding PRC	Corresponding FIC
Three-Phase AC 400V(380V~480V)					
HD2000-30D02504+L300	250	AC	400*2200*650	HD2000-13D01454	HD2000-15D01454
HD2000-30D02504+L301	250			HD2000-13D01774	HD2000-15D01774
HD2000-30D02504+L302	250			HD2000-13D02134	HD2000-15D02134
HD2000-30D04004+L303	400			HD2000-13D02584	HD2000-15D02584
HD2000-30D04004+L304	400			HD2000-13D03454	HD2000-15D03454
HD2000-30D06304+L305	630	BC	600*2200*650	HD2000-13D04814	HD2000-15D04814
HD2000-30D06304+L306	630			HD2000-13D06094	HD2000-14D06094
HD2000-30D12504+L307	1250			HD2000-13D07224	HD2000-14D07224
HD2000-30D12504+L308	1250			HD2000-13D08024	HD2000-14D08024
HD2000-30D12504+L309	1250			HD2000-13D10104	HD2000-14D10104
HD2000-30D16004+L310	1600	BC	600*2200*650	HD2000-13D12834	HD2000-14D12834
HD2000-30D16004+L311	1600			HD2000-13D14434	HD2000-14D14434

HD2000 Cabinet Selection (Air-Cooled)

The variable frequency cabinets of the HD2000 series air-cooled inverter include the single-drive variable frequency cabinet and the multi-drive variable frequency cabinet.

The single-drive variable frequency cabinet consists of an incoming control cabinet and a variable frequency cabinet, which is a standard configuration product. The multi-drive variable frequency cabinet consists of an incoming control cabinet, a rectifier cabinet and a motor drive cabinet, which can be freely configured. Depending on the rectification method, the selection of incoming control cabinet also varies.

The single-drive variable frequency cabinet and the configured multi-drive variable frequency cabinet are complete products, which can be used by users directly.

Two-Quadrant Single-Drive Variable Frequency Cabinet (VFC)

Model	Rated		Light Load		Heavy Load		Frame Type	Dimensions W*H*D (mm)
	Current (A)	Motor Power (kW)	Current (A)	Motor Power (kW)	Current (A)	Motor Power (kW)		
Three-Phase AC 400V (380V~480V)								
HD2000-33D01564 +HD2000-30D01604+L401	156	75	151	75	139	55	FU	800*2200*650
HD2000-33D01804 +HD2000-30D02504+L402	180	90	175	90	160	75		
HD2000-33D02144 +HD2000-30D02504+L403	214	110	208	110	191	90		
HD2000-33D02654+ HD2000-30D04004+L404	265	132	257	132	236	110		
HD2000-33D03124 +HD2000-30D04004+L405	312	160	303	160	278	132		
HD2000-33D03804 +HD2000-30D04004+L406	380	200	369	200	338	160	GU	800*2200*650
HD2000-33D04904 +HD2000-30D06304+L407	490	250	475	250	436	200		
HD2000-33D06054 +HD2000-30D12504+L408	605	315	587	315	538	250	HU	1000*2200*650
HD2000-33D07454 +HD2000-30D12504+L409	745	400	723	400	663	315		
HD2000-33D08404 +HD2000-30D12504+L410	840	450	815	450	748	400		
Three-Phase AC 690V (500V~690V)								
HD2000-33D00866 +HD2000-30D01606+L421	86	75	83	75	77	55	FU	800*2200*650
HD2000-33D01016 +HD2000-30D01606+L422	101	90	97	90	89	75		
HD2000-33D01216 +HD2000-30D01606+L423	121	110	117	110	108	90		
HD2000-33D01516 +HD2000-30D01606+L424	151	132	147	132	134	110		
HD2000-33D01766 +HD2000-30D02506+L425	176	160	171	160	157	132		
HD2000-33D02156 +HD2000-30D02506+L426	215	200	209	200	191	160	GU	800*2200*650
HD2000-33D02606 +HD2000-30D04006+L427	260	250	252	250	231	200		
HD2000-33D03306 +HD2000-30D04006+L428	330	315	320	315	294	250	HU	1000*2200*650
HD2000-33D04106 +HD2000-30D06306+L429	410	400	398	400	365	315		
HD2000-33D04656 +HD2000-30D06306+L430	465	450	451	450	414	400		
HD2000-33D05756 +HD2000-30D06306+L431	575	560	558	560	512	450		

Note:

(1) The standard single-drive variable frequency cabinet is configured with an isolation switch. If a circuit breaker is required, please specify it when placing an order.

(2) To configure a brake unit, add "B" at the end of the model, such as "HD2000-33D00866B+HD2000-30D01606+L421"

☉ **Multi-Drive Incoming Control Cabinet (ICC) - Used for BRC**

Model	Rated Current (A)	Frame Type	Dimensions W*H*D (mm)	Corresponding BRC		
Three-Phase AC 400V (380V~480V)						
HD2000-30D02504+L100	250	AC	400*2200*650	HD2000-11D01624		
HD2000-30D02504+L101	250			HD2000-11D01984		
HD2000-30D02504+L102	250			HD2000-11D02384		
HD2000-30D04004+L103	400			HD2000-11D02894		
HD2000-30D04004+L104	400			HD2000-11D03614		
HD2000-30D06304+L105	630			HD2000-11D04514		
HD2000-30D12504+L106	1250			BC	600*2200*650	HD2000-11D07224
HD2000-30D12504+L107	1250					HD2000-11D10104
HD2000-30D16004+L108	1600	HD2000-11D12814				
HD2000-30D16004+L109	1600	HD2000-10D16244				
Three-Phase AC 690V (500V~690V)						
HD2000-30D01606+L110	160	AC	400*2200*650	HD2000-11D00946		
HD2000-30D01606+L111	160			HD2000-11D01156		
HD2000-30D01606+L112	160			HD2000-11D01386		
HD2000-30D02506+L113	250			HD2000-11D01676		
HD2000-30D02506+L114	250			HD2000-11D02096		
HD2000-30D04006+L115	400			HD2000-11D02616		
HD2000-30D04006+L116	400			HD2000-11D03716		
HD2000-30D06306+L117	630			HD2000-11D05866		
HD2000-30D12506+L118	1250			BC	600*2200*650	HD2000-11D09416
HD2000-30D12506+L119	1250					HD2000-11D11516
HD2000-30D16006+L120	1600	HD2000-10D15696				

☉ **Multi-Drive Incoming Control Cabinet (ICC) - Used for PRC**

Model	Rated Current (A)	Frame Type	Dimensions W*H*D (mm)	Corresponding PRC	Corresponding FIC
Three-Phase AC 690V (500V~690V)					
HD2000-30D01606+L312	160	AC	400*2200*650	HD2000-13D00856	HD2000-15D00856
HD2000-30D01606+L313	160			HD2000-13D01036	HD2000-15D01036
HD2000-30D01606+L314	160			HD2000-13D01246	HD2000-15D01246
HD2000-30D01606+L315	160			HD2000-13D01506	HD2000-15D01506
HD2000-30D02506+L316	250			HD2000-13D01886	HD2000-15D01886
HD2000-30D04006+L317	400			HD2000-13D02326	HD2000-15D02326
HD2000-30D04006+L318	400			HD2000-13D02936	HD2000-15D02936
HD2000-30D04006+L319	400			HD2000-13D03726	HD2000-15D03726
HD2000-30D06306+L320	630			HD2000-13D04656	HD2000-15D04656
HD2000-30D06306+L321	630			HD2000-13D05756	HD2000-15D05756
HD2000-30D12506+L322	1250	BC	600*2200*650	HD2000-13D07446	HD2000-14D07446
HD2000-30D12506+L323	1250			HD2000-13D10236	HD2000-14D10236
HD2000-30D16006+L324	1600			HD2000-13D13026	HD2000-14D13026
HD2000-30D16006+L325	1600			HD2000-13D14886	HD2000-14D14886

☉ **Multi-Drive Basic Rectifier Cabinet (BRC)**

Model	Rated Power (kW)	AC Current		DC Current			Frame Type	Dimensions W*H*D (mm)
		Rated Current I _N (A)	Max. Current I _{max} (A)	Rated Current I _{N,DC} (A)	Basic Load Current I _{L,DC} (A)	Max. Current I _{max,DC} (A)		
Three-Phase AC 400V (380V~480V)								
HD2000-11D01624	90	162	244	193	151	290	AC	400*2200*650
HD2000-11D01984	110	198	298	236	184	354		
HD2000-11D02384	132	238	357	283	221	425		
HD2000-11D02894	160	289	433	343	268	515		
HD2000-11D03614	200	361	541	429	335	644		
HD2000-11D04514	250	451	677	536	418	804		
HD2000-11D07224	400	722	1083	858	669	1287		
HD2000-11D10104	560	1010	1516	1201	937	1802		
HD2000-11D12814	710	1281	1922	1523	1188	2285		
HD2000-10D16244 ⁽¹⁾	900	1624	2436	1931	1506	2896		
Three-Phase AC 690V (500V~690V)								
HD2000-11D00946	90	94	141	112	87	168	AC	400*2200*650
HD2000-11D01156	110	115	173	137	107	205		
HD2000-11D01386	132	138	207	164	128	246		
HD2000-11D01676	160	167	251	199	155	298		
HD2000-11D02096	200	209	314	249	194	373		
HD2000-11D02616	250	261	392	311	243	466		
HD2000-11D03716	355	371	557	441	344	662		
HD2000-11D05866	560	586	879	696	543	1045		
HD2000-11D09416	900	941	1412	1119	873	1679		
HD2000-11D11516	1100	1151	1726	1368	1067	2052		
HD2000-10D15696 ⁽²⁾	1500	1569	2353	1865	1455	2798		

Note:
 (1) The basic rectifier unit of 400V/900kW adopts diode rectification.
 (2) The basic rectifier unit of 690V/1500kW (and above) adopts diode rectification.

HD2000 Cabinet Selection (Air-Cooled)

Multi-Drive Smart Rectifier Cabinet (SRC)

Model	Rated Power (kW)	AC Current		DC Current			Frame Type	Dimensions W*H*D (mm)
		Rated Current I _N (A)	Max. Current I _{max} (A)	Rated Current I _{N,DC} (A)	Basic Load Current I _{h,DC} (A)	Max. Current I _{max,DC} (A)		
Three-Phase AC 400V (380V~480V)								
HD2000-12D01654	90	165	246	195	174	293	AC	400*2200*650
HD2000-12D02014	110	201	302	238	212	357		
HD2000-12D02424	132	242	363	287	255	431		
HD2000-12D02934	160	293	440	348	310	522		
HD2000-12D03644	200	364	547	433	386	650		
HD2000-12D04564	250	456	683	542	482	813		
HD2000-12D06474	355	647	970	769	685	1154		
HD2000-12D09114	500	911	1367	1083	964	1625		
HD2000-12D11484	630	1148	1722	1365	1215	2048	BC	600*2200*650
HD2000-12D14584	800	1458	2187	1734	1543	2600	CC	800*2200*650
Three-Phase AC 690V (500V~690V)								
HD2000-12D00966	90	96	143	113	101	170	AC	400*2200*650
HD2000-12D01176	110	117	176	139	124	209		
HD2000-12D01406	132	140	210	166	148	249		
HD2000-12D01706	160	170	255	202	180	303		
HD2000-12D02116	200	211	317	251	224	377		
HD2000-12D02646	250	264	396	314	280	471		
HD2000-12D03336	315	333	499	396	352	594		
HD2000-12D04756	450	475	713	565	503	848		
HD2000-12D07506	710	750	1125	892	794	1338		
HD2000-12D10576	1000	1057	1585	1256	1118	1884		
HD2000-12D14796	1400	1479	2219	1759	1565	2638	CC	800*2200*650
HD2000-12D16906	1600	1690	2535	2009	1788	3014		

Multi-Drive PWM Rectifier Cabinet (PRC)

Model	Rated Power (kW)	AC Current		DC Current			Frame Type	Dimensions W*H*D (mm)
		Rated Current I _N (A)	Max. Current I _{max} (A)	Rated Current I _{N,DC} (A)	Basic Load Current I _{h,DC} (A)	Max. Current I _{max,DC} (A)		
Three-Phase AC 400V (380V~480V)								
HD2000-13D01454	90	145	217	162	144	242	AC	400*2200*650
HD2000-13D01774	110	177	265	198	176	296		
HD2000-13D02134	132	213	320	238	212	357		
HD2000-13D02584	160	258	387	288	256	432		
HD2000-13D03454	200	345	518	386	343	579		
HD2000-13D04814	300	481	722	539	480	808		
HD2000-13D06094	380	609	914	683	607	1024		
HD2000-13D07224	450	722	1083	808	719	1212		
HD2000-13D08024	500	802	1203	898	799	1347	BC	600*2200*650
HD2000-13D10104	630	1010	1516	1132	1007	1697	CC	800*2200*650
HD2000-13D12834	800	1283	1925	1437	1279	2156		
HD2000-13D14434	900	1443	2165	1617	1439	2425		

Multi-Drive PWM Rectifier Cabinet (PRC)

Model	Rated Power (kW)	AC Current		DC Current			Frame Type	Dimensions W*H*D (mm)
		Rated Current I _N (A)	Max. Current I _{max} (A)	Rated Current I _{N,DC} (A)	Basic Load Current I _{h,DC} (A)	Max. Current I _{max,DC} (A)		
Three-Phase AC 690V (500V~690V)								
HD2000-13D00856	90	85	126	94	83	141	AC	400*2200*650
HD2000-13D01036	110	103	153	115	102	172		
HD2000-13D01246	132	124	186	138	123	207		
HD2000-13D01506	160	150	225	167	149	251		
HD2000-13D01886	200	188	282	209	186	314		
HD2000-13D02326	250	232	349	260	232	390		
HD2000-13D02936	315	293	439	328	292	492		
HD2000-13D03726	400	372	558	417	371	625		
HD2000-13D04656	500	465	697	521	463	781	BC	600*2200*650
HD2000-13D05756	560	575	862	644	573	966		
HD2000-13D07446	800	744	1116	833	741	1250	CC	800*2200*650
HD2000-13D10236	1100	1023	1534	1145	1019	1718		
HD2000-13D13026	1400	1302	1952	1458	1297	2187		
HD2000-13D14886	1600	1488	2231	1667	1484	2501		

Multi-Drive LCL Filter Interface Cabinet (FIC)

Model	AC Current		Matched Rectifier Unit Model	Frame Type	Dimensions W*H*D (mm)
	Rated Current I _N (A)	Max. Current I _{max} (A)			
Three-Phase AC 400V (380V~480V)					
HD2000-15D01454	145	216	HD2000-13D01454	AC	400*2200*650
HD2000-15D01774	177	264	HD2000-13D01774		
HD2000-15D02134	213	318	HD2000-13D02134		
HD2000-15D02584	258	386	HD2000-13D02584		
HD2000-15D03454	345	518	HD2000-13D03454		
HD2000-15D04814	481	722	HD2000-13D04814		
HD2000-14D06094	609	914	HD2000-13D06094		
HD2000-14D07224	722	1083	HD2000-13D07224		
HD2000-14D08024	802	1203	HD2000-13D08024		
HD2000-14D10104	1010	1515	HD2000-13D10104		
HD2000-14D12834	1283	1925	HD2000-13D12834	BC	600*2200*650
HD2000-14D14434	1443	2165	HD2000-13D14434		
Three-Phase AC 690V (500V~690V)					
HD2000-15D00856	85	126	HD2000-13D00856	AC	400*2200*650
HD2000-15D01036	103	155	HD2000-13D01036		
HD2000-15D01246	124	184	HD2000-13D01246		
HD2000-15D01506	150	223	HD2000-13D01506		
HD2000-15D01886	188	279	HD2000-13D01886		
HD2000-15D02326	232	349	HD2000-13D02326		
HD2000-15D02936	293	439	HD2000-13D02936		
HD2000-15D03726	372	558	HD2000-13D03726		
HD2000-14D04656	465	697	HD2000-13D04656	BC	600*2200*650
HD2000-14D05756	575	862	HD2000-13D05756		
HD2000-14D07446	744	1116	HD2000-13D07446		
HD2000-14D10236	1023	1534	HD2000-13D10236		
HD2000-14D13026	1302	1952	HD2000-13D13026		
HD2000-14D14886	1488	2231	HD2000-13D14886		

HD2000 Cabinet Selection (Air-Cooled)

Chassis Type Motor Drive Cabinet (MDC)

Model	Rated		Light Load		Heavy Load		Frame Type	Dimensions W*H*D (mm)
	Current (A)	Motor Power (kW)	Current (A)	Motor Power (kW)	Current (A)	Motor Power (kW)		
Three-Phase AC 400V (380V~480V), DC Circuit Voltage 510V~720V								
HD2000-16D01564(B)	156	75	151	75	139	55	AC	400*2200*650
HD2000-16D01804(B)	180	90	175	90	160	75		
HD2000-16D02144	214	110	208	110	191	90		
HD2000-16D02654	265	132	257	132	236	110		
HD2000-16D03124	312	160	303	132	278	132		
HD2000-16D03804	380	200	369	200	338	160		
HD2000-16D04904	490	250	475	250	436	200		
HD2000-16D06054	605	315	587	315	538	250		
HD2000-16D07454	745	400	723	400	663	315		
HD2000-16D08404	840	450	815	450	748	400		
HD2000-16D09854	985	560	955	560	877	450	BC	600*2200*650
HD2000-16D12604	1260	710	1222	710	1121	560		
HD2000-16D14054	1405	800	1363	800	1250	710		
HD2000-16D14054	1405	800	1363	800	1250	710		
Three-Phase AC 690V (500V~690V), DC Circuit Voltage 675V~1050V								
HD2000-16D00866(B)	86	75	83	75	77	55	AC	400*2200*650
HD2000-16D01016(B)	101	90	97	90	89	75		
HD2000-16D01216	121	110	117	110	108	90		
HD2000-16D01516	151	132	147	132	134	110		
HD2000-16D01766	176	160	171	160	157	132		
HD2000-16D02156	215	200	209	200	191	160		
HD2000-16D02606	260	250	252	250	231	200		
HD2000-16D03306	330	315	320	315	294	250		
HD2000-16D04106	410	400	398	400	365	315		
HD2000-16D04656	465	450	451	450	414	400		
HD2000-16D05756	575	560	558	560	512	450	BC	600*2200*650
HD2000-16D07356	735	710	713	710	654	630		
HD2000-16D08106	810	800	786	800	721	710		
HD2000-16D09106	910	900	883	900	810	800		
HD2000-16D10256	1025	1000	994	1000	912	900	CC	800*2200*650
HD2000-16D12706	1270	1200	1232	1200	1130	1000		
HD2000-16D14826	1482	1400	1438	1400	1319	1200		
HD2000-16D14826	1482	1400	1438	1400	1319	1200		

- Note:
- To purchase a compact type motor drive cabinet, add "-S" at the end of the corresponding chassis type motor drive cabinet model, such as "HD2000-16D01804-S".
 - To purchase a motor drive cabinet with an input reactor, add "+L" at the end of the model, such as "HD2000-16D01804+L".
 - To purchase a motor drive cabinet with a bus DC switch, add "+Q" at the end of the model, such as "HD2000-16D01804+Q".

Output Inductor Cabinet (OFC)

Model	Rated Current (A)	Frame Type	Dimensions W*H*D (mm)	Corresponding MDC
Three-Phase AC 400V (380V~480V)				
HD2000-21D03804	380	AC	400*2200*650	HD2000-16D03804
HD2000-21D04904	490			HD2000-16D04904
HD2000-21D06054	605			HD2000-16D06054
HD2000-21D07454	745			HD2000-16D07454
HD2000-21D08404	840	BC	600*2200*650	HD2000-16D08404
HD2000-21D09854	985			HD2000-16D09854
HD2000-21D12604	1260			HD2000-16D12604
HD2000-21D14054	1405			HD2000-16D14054
Three-Phase AC 690V (500V~690V)				
HD2000-21D02156	215	AC	400*2200*650	HD2000-16D02156
HD2000-21D02606	260			HD2000-16D02606
HD2000-21D03306	330			HD2000-16D03306
HD2000-21D04106	410			HD2000-16D04106
HD2000-21D04656	465	BC	600*2200*650	HD2000-16D04656
HD2000-21D05756	575			HD2000-16D05756
HD2000-21D07356	735			HD2000-16D07356
HD2000-21D08106	810			HD2000-16D08106
HD2000-21D09106	910	BC	600*2200*650	HD2000-16D09106
HD2000-21D10256	1025			HD2000-16D10256
HD2000-21D12706	1270			HD2000-16D12706
HD2000-21D14826	1482			HD2000-16D14826

- Note:
- The output inductor cabinet (OFC) is used for parallel connection of motor drive cabinet (MDC) or du/dt suppression of long distance output.
 - "21D" means one output inductor for one cabinet. If two output inductors need to be installed in one cabinet, the original model should be modified to "22D", such as "HD2000-22D03804".
 - To add an output inductor for motor drive unit with rated power of 160kW and below, add "+L" at the end of the model, which means to integrate the output inductor in the motor drive cabinet.
 - To add an output inductor for motor drive unit with rated power of 160kW and above, separate output inductor can be selected. Or you can add "+L" at the end of the model, which means to integrate the output inductor in the motor drive cabinet.

Power Brake Cabinet (PBC)

Model	Rated Power P _{DB} (kW)	Peak Power P ₁₅ (kW)	Min. Braking Resistance (Ω)	Braking Start Voltage (V)	Braking End Voltage (V)	Frame Type	Dimensions W*H*D (mm)
AC Input Voltage (380V~480V)							
HD2000-18D06504	200 (480V) 151 (380V)	730 (480V) 552 (380V)	0.82	774 (480V) 673 (380V)	735 (480V) 639 (380V)	AC	400*2200*650
HD2000-18D12004	370 (480V) 280 (380V)	1380 (480V) 1043 (380V)	0.43	774 (480V) 673 (380V)	735 (480V) 639 (380V)		
AC Input Voltage (500V~600V)							
HD2000-18D05806	220 (600V) 166 (500V)	830 (600V) 628 (500V)	1.13	967 (600V) 841 (500V)	919 (600V) 799 (500V)	AC	400*2200*650
HD2000-18D11006	420 (600V) 318 (500V)	1580 (600V) 1195 (500V)	0.59	967 (600V) 841 (500V)	919 (600V) 799 (500V)		
AC Input Voltage (660V~690V)							
HD2000-18D05206	240 (690V) 205 (660V)	920 (690V) 785 (660V)	1.46	1158 (690V) 1070 (660V)	1100 (690V) 1017 (660V)	AC	400*2200*650
HD2000-18D10006	460 (690V) 393 (660V)	1700 (690V) 1451 (660V)	0.79	1158 (690V) 1070 (660V)	1100 (690V) 1017 (660V)		

HD2000 Unit Selection (Liquid-Cooled)

The units of the HD2000 series liquid-cooled inverter include multi-drive AC-DC rectifier units and DC-AC motor drive units.

These units need to be equipped with corresponding power distribution protection devices, and users can only use them normally after secondary integration.

Frame Type and Weight

Frame type	Weight (kg)	Frame type	Weight (kg)	Frame Type	Weight (kg)
NU	55	PU	260	SU	97
OU	160	RU	126	TU	306

Multi-Drive Basic Rectifier Unit (BRU)

Model	Rated Power (kW)	AC Current		DC Current			Frame Type	Dimensions W*H*D (mm)
		Rated Current I _N (A)	Max. Current I _{max} (A)	Rated Current I _{N,DC} (A)	Basic Load Current I _{h,DC} (A)	Max. Current I _{max,DC} (A)		
Liquid-Cooled Model - Three-Phase AC 400V (380V~480V)								
HD2000-11B10104L	560	1010	1516	1201	937	1802	RU	245*1052*590
HD2000-11B12814L	710	1281	1922	1523	1188	2285		
HD2000-11B16244L	900	1624	2436	1931	1506	2896		
Liquid-Cooled Model - Three-Phase AC 690V (500V~690V)								
HD2000-11B09416L	900	941	1412	1119	837	1679	RU	245*1052*590
HD2000-11B11516L	1100	1151	1726	1368	1067	2052		
HD2000-11B15696L	1500	1569	2353	1865	1455	2798		
HD2000-10B20916L ⁽¹⁾	2000	2091	3137	2486	1939	3729	OU	332*894*588
HD2000-10B23246L ⁽¹⁾	2500	2324	3486	2763	2155	4145		

Note: The basic rectifier unit of 690V/2000kW (and above) adopts diode rectification, and external precharging circuit is required.

Multi-Drive Smart Rectifier Unit (SRU)

Model	Rated Power (kW)	AC Current (A)		DC Current (A)			Frame Type	Dimensions (W*H*D mm)
		Rated Current I _N (A)	Max. Current I _{max} (A)	Rated DC Current I _{N,DC} (A)	Basic Load Current I _{h,DC} (A)	Max. Current I _{max,DC} (A)		
Liquid-Cooled Model - Three-Phase AC 400V (380V~480V)								
HD2000-12B03644L	200	364	547	433	386	650	SU	225*867*590
HD2000-12B04564L	250	456	683	542	482	813		
HD2000-12B06474L	355	647	970	769	685	1154		
HD2000-12B09114L	500	911	1367	1083	964	1625		
Liquid-Cooled Model - Three-Phase AC 690V (500V~690V)								
HD2000-12B02646L	250	264	396	314	280	471	SU	225*867*590
HD2000-12B03336L	315	333	499	396	352	594		
HD2000-12B04756L	450	475	713	565	503	848		
HD2000-12B05756L	560	575	862	644	573	966		
HD2000-12B12686L	1200	1268	1902	1507	1342	2261	PU	548*920*590
HD2000-12B14796L	1400	1479	2219	1759	1565	2638		
HD2000-12B16906L	1600	1690	2535	2009	1788	3014		
HD2000-12B21136L	2000	2113	3170	2512	2236	3769		

Multi-Drive PWM Rectifier Unit (PRU)

Model	Rated Power (kW)	AC Current		DC Current			Frame Type	Dimensions W*H*D (mm)
		Rated Current I _N (A)	Max. Current I _{max} (A)	Rated Current I _{N,DC} (A)	Basic Load Current I _{h,DC} (A)	Max. Current I _{max,DC} (A)		
Liquid-Cooled model - Three-Phase AC 400V (380V~480V)								
HD2000-13B03774L	235	377	565	422	376	633	SU	225*867*590
HD2000-13B04814L	300	481	722	539	480	808		
HD2000-13B06094L	380	609	914	683	607	1024		
HD2000-13B07224L	450	722	1083	808	719	1212		
HD2000-13B08024L	500	802	1203	898	799	1347		
Liquid-Cooled Model - Three-Phase AC 690V (500V ~ 690V)								
HD2000-13B02326L	250	232	349	260	232	390	SU	225*867*590
HD2000-13B02936L	315	293	439	328	292	492		
HD2000-13B03726L	400	372	558	417	371	625		
HD2000-13B04656L	500	465	697	521	463	781		
HD2000-13B05756L	560	575	862	644	573	966		
HD2000-13B11166L	1200	1116	1674	1250	1112	1874	PU	548*920*590
HD2000-13B13026L	1400	1302	1952	1458	1297	2187		
HD2000-13B14886L	1600	1488	2231	1667	1484	2501		
HD2000-13B18596L	2000	1859	2789	2083	1854	3124		
Liquid-Cooled Model - Three-Phase AC 1140V								
HD2000-13B15759L	2800	1575	2362	1760	1566	2640	TU	655*1102*604
Liquid-Cooled Model - Three-Phase AC 1380V								
HD2000-13B1575AL	3400	1575	2362	1760	1566	2640	TU	655*1102*604

HD2000 Unit Selection (Liquid-Cooled)

Chassis Type Motor Drive Unit (MDU)

Model	Rated		Light Load		Heavy Load		Frame Type	Dimensions W*H*D (mm)
	Current (A)	Motor Power (kW)	Current (A)	Motor Power (kW)	Current (A)	Motor Power (kW)		
Liquid-Cooled Model - Three-Phase AC 400V (380V~480V), DC Circuit Voltage 510V~720V								
HD2000-16B03804L	380	200	369	200	338	160	SU	225*867*590
HD2000-16B04904L	490	250	475	250	436	200		
HD2000-16B06054L	605	315	587	315	538	250		
HD2000-16B07454L	745	400	723	400	663	315		
HD2000-16B08404L	840	450	815	450	748	400		
Liquid-Cooled Model - Three-Phase AC 690V (500V~690V), DC Circuit Voltage 675V~1050V								
HD2000-16B02606L	260	250	252	250	231	200	SU	225*867*590
HD2000-16B03306L	330	315	320	315	294	250		
HD2000-16B04106L	410	400	398	400	365	315		
HD2000-16B04656L	465	450	451	450	414	400		
HD2000-16B05756L	575	560	558	560	512	450		
HD2000-16B08106L	810	800	786	800	721	710	PU	548*920*590
HD2000-16B10256L	1025	1000	994	1000	912	900		
HD2000-16B12706L	1270	1200	1232	1200	1130	1000		
HD2000-16B14826L	1482	1400	1438	1400	1319	1200		
HD2000-16B17996L	1799	1700	1745	1700	1601	1400		
Liquid-Cooled model - Three-Phase AC 1140V								
HD2000-16B14899L	1489	2400	1444	2400	1325	2130	TU	655*1102*604
Liquid-Cooled model - Three-Phase AC 1380V								
HD2000-16B1489AL	1489	2800	1444	2800	1325	2490	TU	655*1102*604

The appropriate capacity and quantity of brake units should be selected separately based on actual requirements.

Power Brake Unit - Centralized

Model	Rated Power P ₀₈ (kW)	Peak Power P ₁₅ (kW)	Min. Braking Resistance (Ω)	Braking Start Voltage (V)	Braking End Voltage (V)	Frame Type	Dimensions W*H*D (mm)
Liquid-Cooled Model - AC Input Voltage (380V~480V)							
HD2000-18B12004L	370 (480V) 280 (380V)	1380 (480V) 1043 (380V)	0.43	774 (480V) 673 (380V)	735 (480V) 639 (380V)	NU	172*761*587
Liquid-Cooled Model - AC Input Voltage (500V~600V)							
HD2000-18B05806L	220 (600V) 166 (500V)	830 (600V) 628 (500V)	1.13	967 (600V) 841 (500V)	919 (600V) 799 (500V)	NU	172*761*587
HD2000-18B11006L	420 (600V) 318 (500V)	1580 (600V) 1195 (500V)	0.59	967 (600V) 841 (500V)	919 (600V) 799 (500V)		
Liquid-Cooled Model - AC Input Voltage (660V~690V)							
HD2000-18B05206L	240 (690V) 205 (660V)	920 (690V) 785 (660V)	1.46	1158 (690V) 1070 (660V)	1100 (690V) 1017 (660V)	NU	172*761*587
HD2000-18B10006L	460 (690V) 393 (660V)	1700 (690V) 1451 (660V)	0.79	1158 (690V) 1070 (660V)	1100 (690V) 1017 (660V)		

Note: Greater braking power can be obtained through paralleling braking units.

Multi-Drive Incoming Control Cabinet (ICC) - Used for BRC

Model	Rated Current (A)	Frame Type	Dimensions W*H*D (mm)	Corresponding MDC
Liquid-Cooled Model - Three-Phase AC 400V (380V~480V)				
HD2000-30D12504L+L605	1250	IC	600*2200*650	HD2000-11D10104L
HD2000-30D12504L+L606	1250			HD2000-11D12814L
HD2000-30D16004L+L607	1600			HD2000-10D16244L
Liquid-Cooled Model - Three-Phase AC 690V (500V~690V)				
HD2000-30D12506L+L625	1250	IC	600*2200*650	HD2000-11D09416L
HD2000-30D12506L+L626	1250			HD2000-11D11516L
HD2000-30D16006L+L627	1600			HD2000-11D15696L
HD2000-30D25006L+L628	2500			HD2000-10D20916L
HD2000-30D25006L+L629	2500			HD2000-10D23246L

Multi-Drive Incoming Control Cabinet (ICC) - Used for SRC

Model	Rated Current (A)	Frame Type	Dimensions W*H*D (mm)	Corresponding SRC
Liquid-Cooled Model - Three-Phase AC 400V (380V~480V)				
HD2000-30D04004L+L705	400	IC	600*2200*650	HD2000-12D03644L
HD2000-30D06304L+L706	630			HD2000-12D04564L
HD2000-30D12504L+L707	1250			HD2000-12D06474L
HD2000-30D12504L+L709	1250			HD2000-12D09114L
Liquid-Cooled Model - Three-Phase AC 690V (500V~690V)				
HD2000-30D04006L+L722	400	IC	600*2200*650	HD2000-12D02646L
HD2000-30D04006L+L723	400			HD2000-12D03336L
HD2000-30D06306L+L724	630			HD2000-12D04756L
HD2000-30D12506L+L725	1250			HD2000-12D05756L
HD2000-30D16006L+L728	1600			HD2000-12D12686L
HD2000-30D16006L+L729	1600			HD2000-12D14796L
HD2000-30D20006L+L730	2000			HD2000-12D16906L
HD2000-30D25006L+L731	2500			HD2000-12D21136L

HD2000 Cabinet Selection (Liquid-Cooled)

Multi-Drive Incoming Control Cabinet (ICC) - Used for PRC

Model	Rated Current (A)	Frame Type	Dimensions W*H*D (mm)	Corresponding PRC	Corresponding FIC
Liquid-Cooled Model - Three-Phase AC 400V (380V~480V)					
HD2000-30D04004L+L805	400	HC	400*2200*650	HD2000-13D03774L	HD2000-15D03774
HD2000-30D06304L+L806	630			HD2000-13D04814L	HD2000-15D04814
HD2000-30D06304L+L807	630			HD2000-13D06094L	HD2000-14D06094
HD2000-30D12504L+L808	1250	IC	600*2200*650	HD2000-13D07224L	HD2000-14D07224
HD2000-30D12504L+L809	1250			HD2000-13D08024L	HD2000-14D08024
Liquid-Cooled Model - Three-Phase AC 690V (500V~690V)					
HD2000-30D04006L+L823	400	HC	400*2200*650	HD2000-13D02326L	HD2000-15D02326
HD2000-30D04006L+L824	400			HD2000-13D02936L	HD2000-15D02936
HD2000-30D04006L+L825	400			HD2000-13D03726L	HD2000-15D03726
HD2000-30D06306L+L826	630			HD2000-13D04656L	HD2000-15D04656
HD2000-30D06306L+L827	630			HD2000-13D05756L	HD2000-15D05756
HD2000-30D12506L+L831	1250	IC	600*2200*650	HD2000-13D11166L	HD2000-14D11166
HD2000-30D16006L+L832	1600			HD2000-13D13026L	HD2000-14D13026
HD2000-30D16006L+L833	1600			HD2000-13D14886L	HD2000-14D14886
HD2000-30D20006L+L834	2000			HD2000-13D18596L	HD2000-14D18596
Liquid-Cooled Model - Three-Phase AC 1140V					
HD2000-30D16009L+L853	1600	IC	750*2200*650	HD2000-13D15759L	HD2000-14D15759L
Liquid-Cooled Model - Three-Phase AC 1380V					
HD2000-30D16009L+L853	1600	IC	750*2200*650	HD2000-13D1575AL	HD2000-14D1575AL

Multi-Drive Basic Rectifier Cabinet (BRC)

Model	Rated Power (kW)	AC Current		DC Current			Frame Type	Dimensions W*H*D (mm)
		Rated Current I _N (A)	Max. Current I _{max} (A)	Rated Current I _{N,DC} (A)	Basic Load Current I _{h,DC} (A)	Max. Current I _{max,DC} (A)		
Liquid-Cooled Model - Three-Phase AC 400V (380V~480V)								
HD2000-11D10104L	560	1010	1516	1201	937	1802	HC	400*2200*650
HD2000-11D12814L	710	1281	1922	1523	1188	2285		
HD2000-11D16244L	900	1624	2436	1931	1506	2896		
Liquid-Cooled Model - Three-Phase AC 690V (500V~690V)								
HD2000-11D09416L	900	941	1412	1119	837	1679	HC	400*2200*650
HD2000-11D11516L	1100	1151	1726	1368	1067	2052		
HD2000-11D15696L	1500	1569	2353	1865	1455	2798		
HD2000-10D20916L ⁽¹⁾	2000	2091	3137	2486	1939	3729		
HD2000-10D23246L ⁽¹⁾	2500	2324	3486	2763	2155	4145		

Note: The basic rectifier unit of 690V/2000kW (and above) adopts diode rectification, and external precharging circuit is required.

Multi-Drive Smart Rectifier Cabinet (SRC)

Model	Rated Power (kW)	AC Current		DC Current			Frame Type	Dimensions W*H*D (mm)
		Rated Current I _N (A)	Max. Current I _{max} (A)	Rated Current I _{N,DC} (A)	Basic Load Current I _{h,DC} (A)	Max. Current I _{max,DC} (A)		
Liquid-Cooled Model - Three-Phase AC 400V (380V~480V)								
HD2000-12D03644L	200	364	547	433	386	650	HC	400*2200*650
HD2000-12D04564L	250	456	683	542	482	813		
HD2000-12D06474L	355	647	970	769	685	1154		
HD2000-12D09114L	500	911	1367	1083	964	1625		
Liquid-Cooled Model - Three-Phase AC 690V (500V~690V)								
HD2000-12D02646L	250	264	396	314	280	471	HC	400*2200*650
HD2000-12D03336L	315	333	499	396	352	594		
HD2000-12D04756L	450	475	713	565	503	848		
HD2000-12D05756L	560	575	862	644	573	966	IC	600*2200*650
HD2000-12D12686L	1200	1268	1902	1507	1342	2261		
HD2000-12D14796L	1400	1479	2219	1759	1565	2638		
HD2000-12D16906L	1600	1690	2535	2009	1788	3014		
HD2000-12D21136L	2000	2113	3170	2512	2236	3769		

Multi-Drive PWM Rectifier Cabinet (PRC)

Model	Rated Power (kW)	AC Current		DC Current			Frame Type	Dimensions W*H*D (mm)
		Rated Current I _N (A)	Max. Current I _{max} (A)	Rated Current I _{N,DC} (A)	Basic Load Current I _{h,DC} (A)	Max. Current I _{max,DC} (A)		
Liquid-Cooled Model - Three-Phase AC 400V (380V~480V)								
HD2000-13D03774L	235	377	565	422	376	633	HC	400*2200*650
HD2000-13D04814L	300	481	722	539	480	808		
HD2000-13D06094L	380	609	914	683	607	1024		
HD2000-13D07224L	450	722	1083	808	719	1212		
HD2000-13D08024L	500	802	1203	898	799	1347		
Liquid-Cooled Model - Three-Phase AC 690V (500V~690V)								
HD2000-13D02326L	250	232	349	260	232	390	HC	400*2200*650
HD2000-13D02936L	315	293	439	328	292	492		
HD2000-13D03726L	400	372	558	417	371	625		
HD2000-13D04656L	500	465	697	521	463	781		
HD2000-13D05756L	560	575	862	644	573	966		
HD2000-13D11166L	1200	1116	1674	1250	1112	1874	IC	600*2200*650
HD2000-13D13026L	1400	1302	1952	1458	1297	2187		
HD2000-13D14886L	1600	1488	2231	1667	1484	2501		
HD2000-13D18596L	2000	1859	2789	2083	1854	3124		
Liquid-Cooled Model - Three-Phase AC 1140V								
HD2000-13D15759L	2800	1575	2362	1760	1566	2640	JC	750*2200*650
Water-Cooled Model - Three-Phase AC 1380V								
HD2000-13D1575AL	3400	1575	2362	1760	1566	2640	JC	750*2200*650

HD2000 Cabinet Selection (Liquid-Cooled)

Multi-Drive LCL Filter Interface Cabinet (FIC)

Model	AC Current		Matched Rectifier Unit Model	Frame Type	Dimensions W*H*D (mm)
	Rated Current I _N (A)	Max. Current I _{max} (A)			
Three-Phase AC 1140V					
HD2000-14D15759L	1575	2363	HD2000-13D15759L	JC	750*2200*650
HD2000-14D1575AL	1575	2363	HD2000-13D1575AL		

Chassis Type Motor Drive Cabinet (MDC)

Model	Rated		Light Load		Heavy Load		Frame Type	Dimensions W*H*D (mm)
	Current (A)	Motor Power (kW)	Current (A)	Motor Power (kW)	Current (A)	Motor Power (kW)		
Liquid-Cooled Model - Three-Phase AC 400V (380V~480V), DC Circuit Voltage 510V~720V								
HD2000-16D03804L	380	200	369	200	338	160	HC	400*2200*650
HD2000-16D04904L	490	250	475	250	436	200		
HD2000-16D06054L	605	315	587	315	538	250		
HD2000-16D07454L	745	400	723	400	663	315		
HD2000-16D08404L	840	450	815	450	748	400		
Liquid-Cooled Model - Three-Phase AC 690V (500V~690V), DC Circuit Voltage 675V~1050V								
HD2000-16D02606L	260	250	252	250	231	200	HC	400*2200*650
HD2000-16D03306L	330	315	320	315	294	250		
HD2000-16D04106L	410	400	398	400	365	315		
HD2000-16D04656L	465	450	451	450	414	400		
HD2000-16D05756L	575	560	558	560	512	450		
HD2000-16D08106L	810	800	786	800	721	710	IC	600*2200*650
HD2000-16D10256L	1025	1000	994	1000	912	900		
HD2000-16D12706L	1270	1200	1232	1200	1130	1000		
HD2000-16D14826L	1482	1400	1438	1400	1319	1200		
HD2000-16D17996L	1799	1700	1745	1700	1601	1400		
Liquid-Cooled Model - Three-Phase AC 1140V								
HD2000-16D14899L	1489	2400	1444	2400	1325	2130	JC	750*2200*650
Liquid-Cooled Model - Three-Phase AC 1380V								
HD2000-16D1489AL	1489	2800	1444	2800	1325	2490	JC	750*2200*650

Note:

- To purchase a motor drive cabinet with an input reactor, add "+L" at the end of the model, such as "HD2000-16D03804L+L".
- To purchase a motor drive cabinet with a bus DC switch, add "+Q" at the end of the model, such as "HD2000-16D03804L+Q".

Power Brake Cabinet (PBC)

Model	Rated Power P _{DB} (kW)	Peak Power P _{1s} (kW)	Min. Braking Resistance (Ω)	Braking Start Voltage (V)	Braking End Voltage (V)	Frame Type	Dimensions W*H*D (mm)		
Liquid-Cooled Model - AC Input Voltage (380V~480V)									
HD2000-18D12004L	370 (480V) 280 (380V)	1380 (480V) 1043 (380V)	0.43	774 (480V) 673 (380V)	735 (480V) 639 (380V)	HC	400*2200*650		
Liquid-Cooled Model - AC Input Voltage (500V~600V)									
HD2000-18D05806L	220 (600V) 166 (500V)	830 (600V) 628 (500V)	1.13	967 (600V) 841 (500V)	919 (600V) 799 (500V)	HC	400*2200*650		
HD2000-18D11606L	220 (600V)*2 166 (500V)*2	830 (600V)*2 628 (500V)*2	1.13*2			IC	600*2200*650		
HD2000-18D17406L	220 (600V)*3 166 (500V)*3	830 (600V)*3 628 (500V)*3	1.13*3	967 (600V) 841 (500V)	919 (600V) 799 (500V)	HC	400*2200*650		
HD2000-18D11006L	420 (600V) 318 (500V)	1580 (600V) 1195 (500V)	0.59			IC	600*2200*650		
HD2000-18D22006L	420 (600V)*2 318 (500V)*2	1580 (600V)*2 1195 (500V)*2	0.59*2			IC	600*2200*650		
HD2000-18D33006L	420 (600V)*3 318 (500V)*3	1580 (600V)*3 1195 (500V)*3	0.59*3	1158 (690V) 1070 (660V)	1100 (690V) 1017 (660V)	HC	400*2200*650		
Liquid-Cooled Model - AC Input Voltage (660V~690V)									
HD2000-18D05206L	240 (690V) 205 (660V)	920 (690V) 785 (660V)	1.46			1158 (690V) 1070 (660V)	1100 (690V) 1017 (660V)	HC	400*2200*650
HD2000-18D10406L	240 (690V)*2 205 (660V)*2	920 (690V)*2 785 (660V)*2	1.46*2					IC	600*2200*650
HD2000-18D15606L	240 (690V)*3 205 (660V)*3	920 (690V)*3 785 (660V)*3	1.46*3	1158 (690V) 1070 (660V)	1100 (690V) 1017 (660V)	HC	400*2200*650		
HD2000-18D10006L	460 (690V) 393 (660V)	1700 (690V) 1451 (660V)	0.79			IC	600*2200*650		
HD2000-18D20006L	460 (690V)*2 393 (660V)*2	1700 (690V)*2 1451 (660V)*2	0.79*2			IC	600*2200*650		
HD2000-18D30006L	460 (690V)*3 393 (660V)*3	1700 (690V)*3 1451 (660V)*3	0.79*3	2140	2034	HC	450*2200*650		
Liquid-Cooled Model - AC Input Voltage 1140V									
HD2000-18D05209L	480	1840	1.46*2			2140	2034	KC	450*2200*650
HD2000-18D10009L	920	3400	0.79*2						

Note: For the liquid-cooled brake cabinet of HD2000-18D10406L, it means that there are 2 individual 240kW brake units installed in the cabinet. When configuring brake resistors, it is necessary to configure 2 brake resistors not less than 1.46Ω, similar to other models (except for the 1140V brake cabinet).

The HD2000 liquid-cooled Unit Cabinet Selection Table

☉ Liquid-Cooled Cabinet + Air Radiator

HD2000 - 40 D 0030 -WW

Series Name:

HD2000: hopeDrive low voltage engineering inverter

Topology/Function:

40: Liquid cooling system

Structure Type:

D: Cabinet product

Heat Exchange Capacity:

0030: 30kW

Cooling Method:

WW: Liquid-to-liquid cooling WA: Liquid-to-air cooling

Model	Heat Exchange Capacity (kW)	Voltage (V)	Cooling Liquid Joint Size (DN)	Dimensions (W*H*D) (mm)	Corresponding Air Radiator Model
HD2000-40D0030-WW	30	380	40	800*2200*650	/
HD2000-40D0030-WA	30	380	40	800*2200*650	HWKS-30
HD2000-40D0060-WW	60	380	40	800*2200*650	/
HD2000-40D0060-WA	60	380	40	800*2200*650	HWKS-60
HD2000-40D0120-WW	120	380	50	800*2200*650	/
HD2000-40D0120-WA	120	380	50	800*2200*650	HWKS-120
HD2000-40D0240-WW	240	380	50	1500*2200*650	/
HD2000-40D0240-WA	240	380	50	1500*2200*650	HWKS-240
HD2000-40D0380-WW	380	380	50	1500*2200*650	/
HD2000-40D0380-WA	380	380	50	1500*2200*650	HWKS-380

☉ Overload Capacity

Low overload: 110% of I_L for 60s or 150% of I_L for 10s in a duty cycle

High overload: 150% of I_H for 60s or 160% of I_H for 10s in a duty cycle

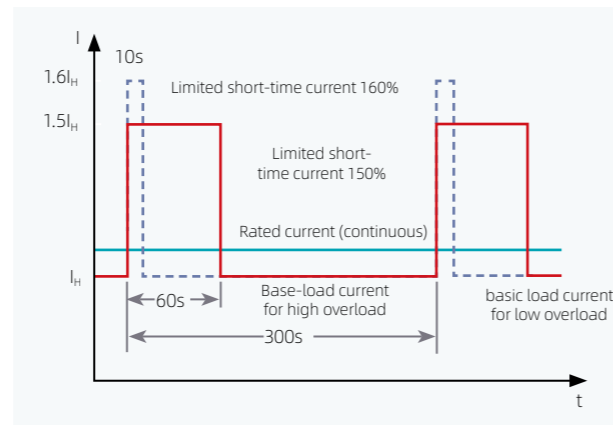
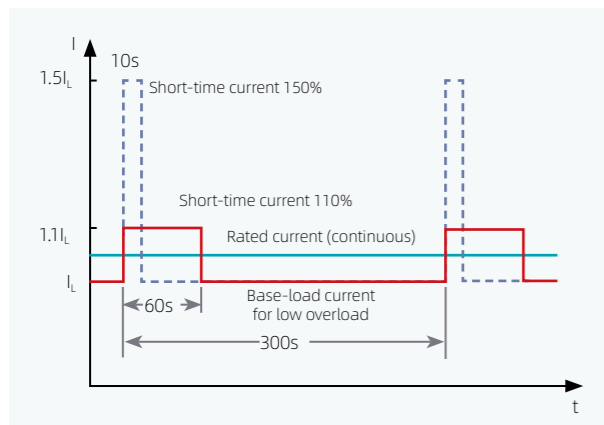

Optional Components

Name	Model	Description
Resolver	HIC200-EIM10	Encoder module (Used in conjunction with HCU20 control unit)
Incremental encoder TTL/HTL	HIC200-EIM30	
Absolute value encoder SSI	HIC200-EIM30	
Temperature signal converter	HIC200-EIM10/HIC200-EIM30	
Resolver card	HVPG-ABZ	Used with compact type motor drive unit
Control unit ⁽¹⁾	HCU20-DP-1-6-H	Supporting profibus-DP communication
	HCU20-NA-1-6	Communication interface Not included
	HCU20-PN-1-6-H	Supporting profinet IO communication
	HCU20-MR-1-6	Supporting modbus RTU communication
	HCU20-CA-1-6	Supporting CANopen communication
	HCU20-CN-1-6	Supporting controlNet communication
	HCU20-DN-1-6	Supporting deviceNet communication
	HCU20-TP-1-6-H	Supporting modbus TCP/IP communication
	HCU20-EC-1-6-H	Supporting etherCAT communication
Communication card ⁽²⁾	HCU20-EN-1-6-H	Supporting etherNet/IP communication
	HVCOM-DP-H	Supporting profibus-DP communication
	HVCOM-PN-H	Supporting profinet IO communication
	HVCOM-CA	Supporting CANopen communication
	HVCOM-CN	Supporting controlNet communication
	HVCOM-DN	Supporting deviceNet communication
	HVCOM-TP-H	Supporting modbus TCP/IP communication
	HVCOM-EC-H	Supporting etherCAT communication
	HVCOM-EN-H	Supporting etherNet/IP communication
Operator panel	HIC200-OP-10	LCD Operator panel (With keyboard base)
Keyboard base	HVKMB	Needed if the operator panel is installed on the cabinet door
Communication adapter	HVCOM-USB	Supporting communication with PC via serial port, Mainly with hopeInsight
3M Shielded ethernet cable	/	Used for connecting the operator panel
5M Dual-layer shielded ethernet cable	/	
2M Fiber optic cable	/	Used for connecting the control unit and power unit
5M Fiber optic cable	/	
8M Fiber optic cable	/	

Note:

(1) Used in compatible with HD2000 series rectifier unit and non-compact type motor drive unit

(2) Used in compatible with HD2000 series compact type motor drive unit

☉ Overload Capacity (Brake Unit)

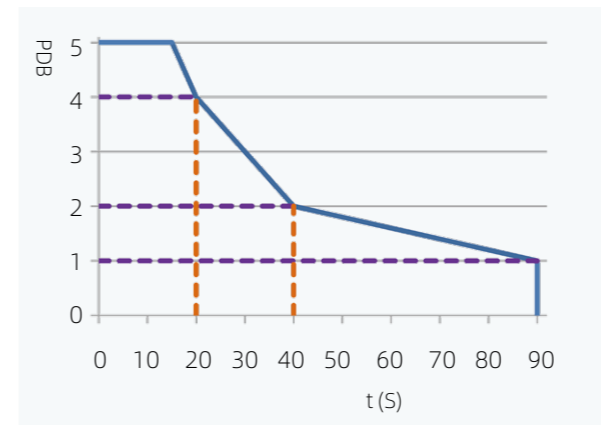

Distributed brake unit performance

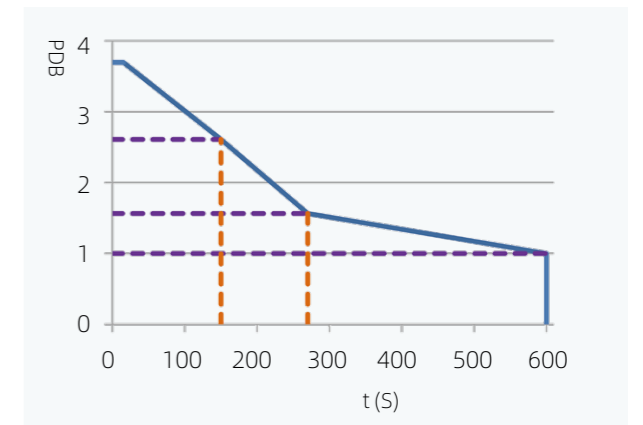

Centralized Brake Unit Performance

HD2000 Configuration Modes

Basic Rectifier Cabinet in Parallel with Common Bus Drive System

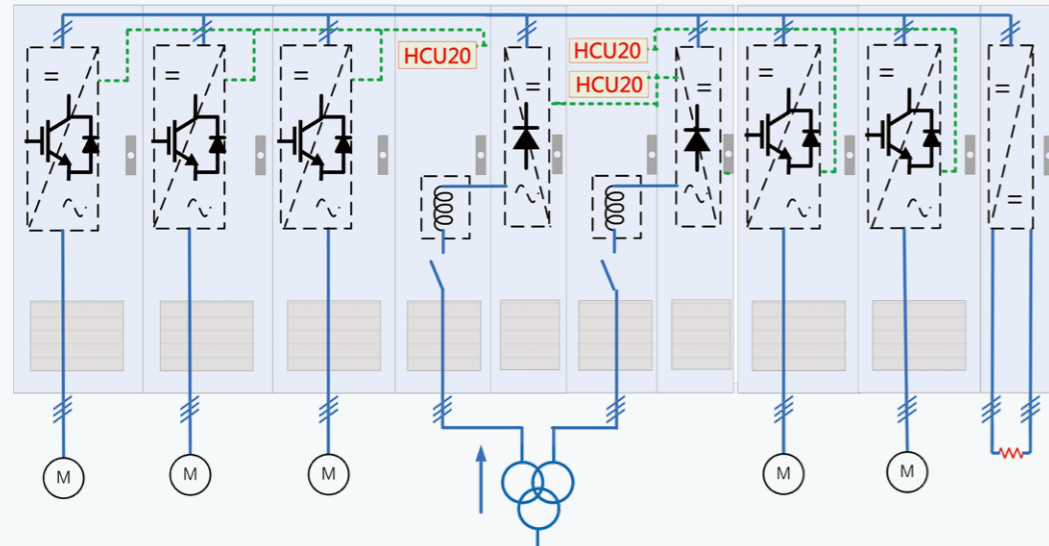

In this configuration mode, each basic rectifier unit cabinet is equipped with an independent incoming control cabinet. The rectifier cabinets form a common DC bus in parallel, and the power brake cabinet is connected to the common bus. The HCU20s are configured in incoming control cabinets respectively, and can be formed into 6-pulse or 12-pulse rectifier units according to different secondary winding and incoming modes of the power supply transformers.

Smart Rectifier Feedback Unit Cabinet in Parallel with Common Bus Drive System

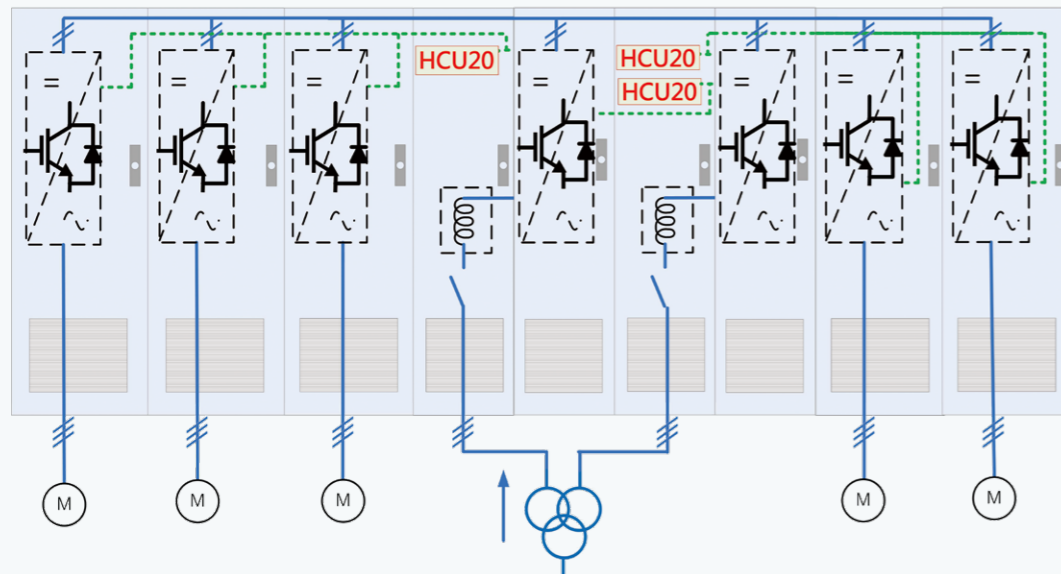

In this configuration mode, each smart rectifier cabinet is equipped with an independent incoming control cabinet. The rectifier cabinets form a common DC bus in parallel. The HCU20s are configured in incoming control cabinets respectively, and can be formed into 6-pulse or 12-pulse rectifier units according to different secondary winding and incoming modes of the power supply transformers.

PWM Rectifier Feedback Unit Cabinet in Parallel with Common DC Bus Drive System

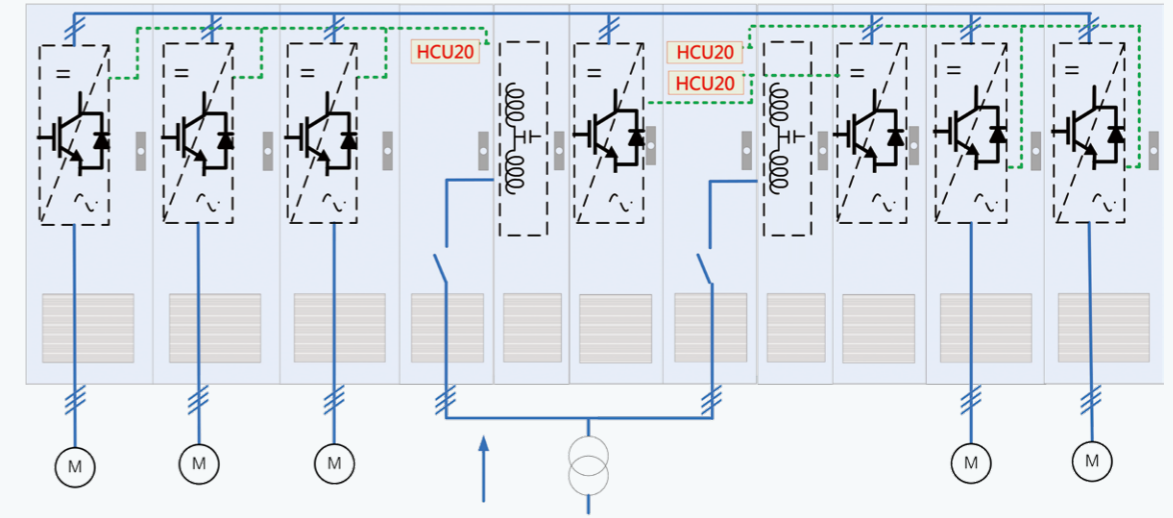

In this configuration mode, each PWM rectifier cabinet is equipped with an independent LCL filter interface cabinet and incoming control cabinet. The rectifier cabinets from a common DC bus in parallel and the HCU20s are configured in incoming control cabinets respectively.

Hybrid Rectifier Unit in Parallel with Common Bus Drive System

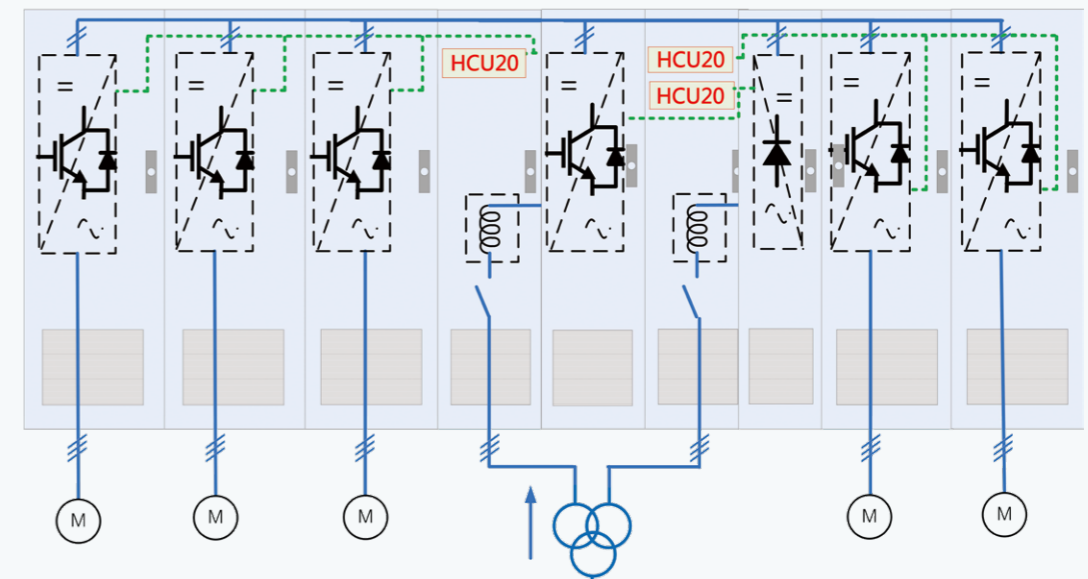

In this configuration mode, basic rectifier cabinets and smart rectifier cabinets are used together. Generally, the capacity of the smart rectifier unit should not exceed 1/3 of that of the basic rectifier unit, and the capacity of the basic rectifier unit should meet requirements of the common DC bus motor drive unit. Each rectifier cabinet is equipped with an independent incoming control cabinet and the rectifier cabinets form a common DC bus. The feedback power is fed back to the grid through the smart rectifier cabinet and the HCU20s are configured in incoming control cabinets respectively.

Office Address: Building 11, Second Industrial Zone, Guanlong Village, Xili Street, Nanshan District, Shenzhen, P.R.China
Postal Code: 518055
Customer Service Hotline: 400-8828-705
Phone: +86-755-86026786
Website: www.hopewind.com

©2024 Hopewind Electric Co., Ltd.
All rights reserved. V4.3.0

