

**HOPEWIND**



# HV510 Series High-Performance Inverter Selection Manual (0.75 kW-132 kW)

Shenzhen Hopewind Electric Co., Ltd. (Stock Code: 603063) focuses on the R&D, manufacturing, sales and services of renewable energy & electric drive products, including products for wind power generation, photovoltaic generation, energy storage, hydrogen production power supply, power quality and electric drive. Furthermore, Hopewind owns integrated independent R&D and testing platforms of high-power power electrical equipment and monitoring systems. Through innovation in technology and service, Hopewind continuously creates value for customers, and has become one of China's most competitive enterprises in the renewable energy field.

In the field of industrial drive, Hopewind provides a wide range of inverters with various voltage and power classes, mainly including HV350 series low-voltage general purpose inverter, HV510 series low-voltage high-performance inverter, HV500 series low-voltage engineering single transmission inverter, HD2000 series low-voltage engineering inverter, HD8000 series medium-voltage engineering inverter, etc., and also provides solutions for 0.75kW~22400kW low-voltage inverter and 4MVA~102MVA (single inverter) medium-voltage inverter. These products can be widely used in metallurgy, petroleum and petrochemical, mining machinery, port lifting, distributed energy generation, large-scale testing platforms, marine equipment, textiles, chemicals, cement, municipal and various other industrial applications.

## 【Honors】



National Science and Technology Progress Award



Laboratory Qualification Approved by CNAS



National High-tech Enterprise

## 【Quality System】



Quality Management System



Environmental Management System

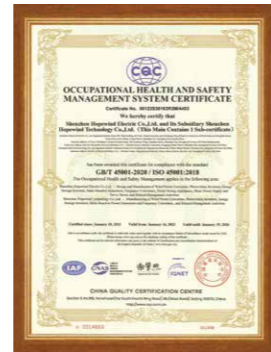

Occupational Health and Safety Management System

## Headquarter-Shenzhen

4 major R&D and manufacturing bases: Shenzhen, Suzhou, Xi'an, Heyuan

30 service bases: Deployed worldwide and providing comprehensive services for global customers



# Contents



HV510 Series High-Performance Inverters .....	04
Product Overview .....	04
Typical Application .....	04
Naming Rules .....	04
Technical Specifications .....	05
Standard Wiring Diagram .....	08
Safety and Reliability .....	09
Excellent Performance .....	09
Extensive Functionality .....	10
Product Selection .....	12
Product Dimensions .....	13
Recommended AC Reactor Selection .....	15
Recommended Braking Resistor Selection .....	14
Optional Accessories .....	16

# HV510 Series High-Performance Inverters

## Product Overview

The HV510 series inverters (the "HV510") are Hopewind's new generation of high-performance vector inverters. They adopt new high-performance open and closed-loop vector control technology and support asynchronous motor and permanent magnet synchronous motor drive control. Their excellent quality, powerful performance, and high power density design enhance the products' ease of use, reliability, environmental adaptability, functional diversity and application flexibility in industrial scenarios. Their design criteria have been improved and their space minimized, comprehensively upgrading the user experience.



## Typical Application

The HV510 can be widely used in the drives of various kinds of automated production equipment in the fields of metallurgy, lifting, petroleum, machine tools, plastics, metal products, papermaking, textile, printing, and packaging.



Metallurgy

Machine Tools

Lifting Equipment

Petroleum

Papermaking

## Naming Rules

**HV510 - A0 4 T 00075 B**

**Inverter series name:**  
HV510: hopeVert Series  
High-Performance Inverter

**Circuit topology and cooling method:**  
A0: Two-quadrant; Air-cooling

**Voltage level:**  
4: 380 V

**Number of phases:**  
T: Three

**Power rating:**  
00075: Heavy load 7.5 kW, light load 11 kW  
00150: Heavy load 15 kW, light load 18.5 kW

**Brake unit information:**  
B: Built-in brake unit  
Blank: No built-in brake unit

# Technical Specifications

## Basic Functions

Input voltage	380 V (-15%) - 480 V (+10%)/three phases
Input power supply frequency	(50 Hz/60 Hz) ±5%
Input voltage imbalance	≤ 3%
Output voltage	0 V to input voltage
Output frequency	0 Hz-1,500 Hz
Motor type	Asynchronous motor, permanent magnet synchronous motor
Control mode	V/F, OLVC (open-loop vector control), CLVC (closed-loop vector control)
Speed range	1:10 for V/F; 1:100 for OLVC; 1:1000 for CLVC
Startup torque	V/F: 100% (0.5 Hz); OLVC: 150% (0.5 Hz); CLVC: 200% (0 Hz)
Torque precision	≤ ±5% under vector control
Torque ripple	≤ ±5% under vector control
Speed stabilizing precision	OLVC: 0.2%; CLVC: 0.01%
Torque response	≤ 5 ms under vector control
Acceleration and deceleration time	0.0 s-3200.0 s; 0.0 min-3200.0 min
Torque boost	0.0%-30.0%
Overload capacity	G-type: 150% for 1 min/5 min, 200% for 3 s/5 min P-type: 110% for 1 min/5 min, 150% for 10 s/5 min
V/F curves	Straight-line type, multi-point type, V/F half separation mode, V/F complete separation mode
Input frequency resolution	Digital setting 0.01 Hz, analog setting 0.01 Hz
Acceleration and deceleration curves	Straight-line and S-curve acceleration and deceleration modes with four types of acceleration and deceleration time and one type of emergency stop deceleration time
Jog control	In some applications, the inverter can run briefly at low speed to test the condition of the equipment
Torque control	Torque control supported during vector control
Simple PLC and multi-segment speed	16-segment speed operation via control terminals
Built-in PID	Easy implementation of closed-loop process control systems
Virtual IO	Eight sets of virtual DI/DO for simple logic control
Overvoltage and overcurrent stall control	Automatic limitation of current and voltage during operation to prevent frequent tripping due to overcurrent or overvoltage
DC braking	Startup DC braking and shutdown DC braking
Pre-excitation	When the inverter starts up, pre-excitation of the motor establishes a magnetic field inside the motor that can effectively improve the torque characteristics of the motor during startup
Overexcitation	This can effectively inhibit the rise of bus voltage during deceleration to avoid frequent overvoltage alerts, and at the same time, enables fast braking upon power failures
Speed tracking	Speed tracking is supported for both asynchronous and synchronous motors and for both vector control and V/F control
Protection functions	Overvoltage suppression, undervoltage suppression, V/F overcurrent suppression, short to ground, phase loss, detection of excessive speed deviation, overvoltage, overcurrent, undervoltage, overload, over-heating, startup, bus undervoltage, bus overvoltage, etc

## Customization Functions

Restart upon power failure	The inverter resumes operation automatically when power is restored after failure
Master-slave control	Master-slave synchronous control between two or more motors
Position lock	Zero-speed hovering can be achieved under CLVC mode
Brake control	Brake control during startup and stop
Parameter copy	Backup and recovery of local user parameters With the help of an external keypad, parameters can be copied between different inverters
Parameters and key lock	Locking of parameters and some/all keys
Keypad UP/DOWN	The keypad UP/DOWN key can be configured to modify parameters
Keypad priority	Commands can be entered using the built-in keypad or an external keypad
Restart after fault auto reset	The inverter can be set to restart automatically after fault auto reset
Stop speed detection	Two stop speed detection modes are supported: detection based on the speed setting value and detection based on the speed feedback value
Braking usage	Both braking and braking resistor protection through braking resistor on-off controlled by frequency
Energy-saving operation	When the motor runs at light load/no load, reducing the output voltage (motor flux) can reduce wear and tear on the motor, and the noise generated by the motor
Timing control	Timing control function allows for a time range of 0-65,000 s/m/h and supports 3 different unit settings
Fixed length control	Control for a given length
Hibernation and wakeup	Used in water supply scenarios
Fan control	Three fan control modes are supported: always working, working automatically and working during inverter running
Overmodulation	Used to increase the inverter output voltage
Random PWM	Used to mitigate motor noise
Multi-motor switchover	Switchover between 2 groups of motor parameters
Multiple encoder types supported	Incremental, resolver, and absolute value
Encoder running in redundancy mode	Automatic switching to OLVC mode in event of encoder failure under CLVC mode
Statistics	Current running time, current power-on time, accumulative running time, accumulative power-on time, accumulative fan running time
User-defined parameters	Parameters can be viewed and changed through the user-defined menu mode and non-continuous addresses can be continuously read and written
Background debugging software	hopeInsight: Supports inverter parameter operation and virtual oscilloscope function. The virtual oscilloscope can perform graphical monitoring of the internal state of the inverter, which, coupled with extensive background monitoring functionality, facilitates on-site data acquisition and debugging
Fault recording	Used to facilitate on-site problem location and analysis
Various communication modes	Modbus RTU (standard); Profibus-DP, CANopen, Profinet IO, Modbus TCP/IP, EtherCAT, EtherNet/IP (optional)
Various optional accessories	External LED keypad, encoder card, communication card, I/O terminal expansion card, etc

## Input/Output Functions

Command sources	Switchover between keypad, terminal, and communication supported
Frequency sources	Supporting switchover between 11 sources: digital setting, analog inputs (AI1/AI2/AI3), pulse reference (DI5), multi-reference, simple PLC, PID, communication, terminal UP/DOWN and frequency source bound to command source
Input terminal functions	66 kinds of DI input terminal functions for logic control
Output terminal functions	48 kinds of DO output terminal functions and 23 kinds of AO and HDO output terminal functions for status indication
Analog input terminals	AI1, AI2: 0 V-10 V/0 (4) mA-20 mA
Digital input terminals	DI1-DI5: 5 programmable digital input terminals with light-coupled isolation, compatible with sourcing and sinking inputs DI5 supports high-speed pulse input with a maximum input frequency of 100 kHz
Digital output terminals	2 open collector output channels; output voltage range: 0 V-24 V; current load capacity: 50 mA DO1 supports high-speed pulse output with a maximum output frequency of 100 kHz
Analog output terminals	Outputs 1-channel current/voltage: 0 V-10 V/ 0(4) mA-20 mA
Relay output	Outputs 1-channel Form C contact: NO+NC
Communication terminals	1 channel (A/B), supporting RS485 communication cable connection
Expansion capability I/O terminal card (optional)	DI6-DI8: 3 programmable digital input channels with light-coupled isolation, compatible with sourcing and sinking inputs DO3: 1 open collector output channel AI3: 1 analog input channel supporting -10 V to +10 V input AO2, AO3: 2 analog output channels supporting 0-10 V/0-20 mA output 1 relay output channel (NO+NC) 1 motor temperature sampling channel supporting PT100, PT1000 and KTY84

## Keypad Display and Operation

LED	Parameter display and setting
External LED keypad	Parameter display, setting and copy
Parameter copy	Quick upload and download of parameters via external LED keypad
Key function selection	The MFK key can be customized to select specific functions

## Environmental Conditions

Altitude	≤ 1000 m: no need for derating 1000-3000 m: derating by 1% per 100 m increased
Ambient temperature	-25°C to +40°C (allowed to run at 40°C to 55°C with derating)
Humidity	15%-95% with no condensation
Vibration	3M3, IEC60721-3-3
Storage temperature	-40°C to +70°C
Place of use	Indoors with no direct sunlight, flammable, corrosive gases or liquids, or conductive particles
Installation	Wall-mounted
Protection rating	IP20
Cooling method	Air-cooling



## Standard Wiring Diagram

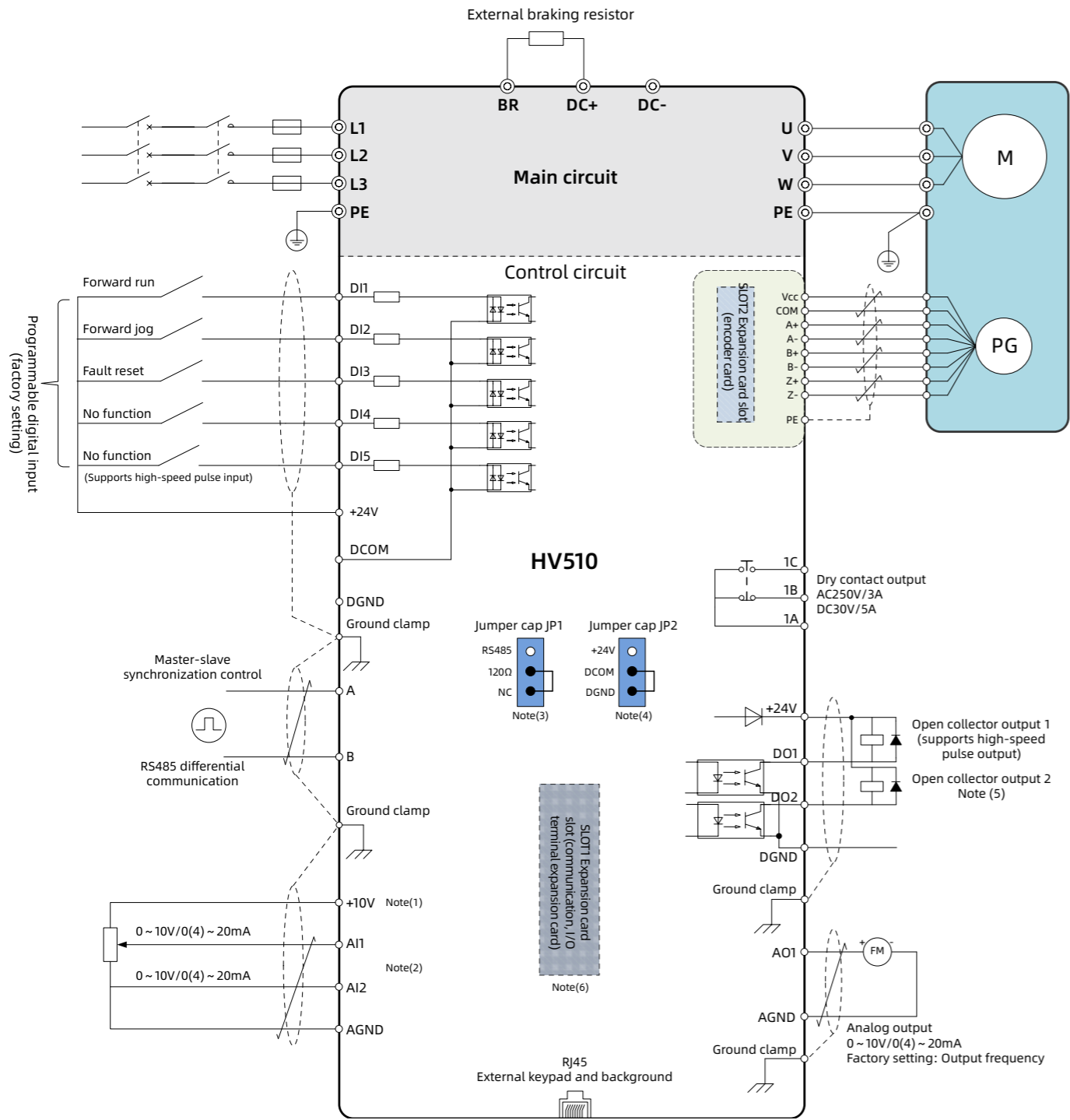

Note (1): The maximum output of +10 V port is 25 mA.

Note (2): Internal resistance of AI1 and AI2 ports (in current mode): 500 Ω.

Note (3): The activation ports for RS485 terminal resistance (120 Ω).

Note (4): For terminals DI1-DI5, NPN or PNP transistor signals can be selected as inputs, and the bias voltage can be selected from the inverter's internal power supply (+24 V terminal) or external power supply (DGND terminal).

Note (5): When the digital output terminals drive the relay, a freewheel diode needs to be added with correct polarity at both ends of the relay coil, otherwise, the internal circuit may be damaged. The driving capacity is not more than 50 mA.

Note (6): The optional I/O terminal expansion card and the communication expansion card share the same expansion card slot, and cannot be installed and used at the same time.

## Safety and Reliability

### Reliable structural design

- Innovative independent air duct design improves the product's heat dissipation performance and environmental adaptability
- Compact type design minimizes the installation space in the cabinet

### Professional thermal design

- Efficient and accurate thermal simulation platform software is adopted to ensure the thermal reliability of the machine
- Advanced thermal testing together with verification techniques and devices effectively verify the theoretical results of the thermal design



### Rigorous temperature rise test

- A stringent full-load and overload verification test program is adopted for temperature rise testing on the machine
- High-temperature load aging test for the product before leaving the factory effectively prevents and intercepts component failures

### Effective anti-interference design

- Built-in C3 filter can effectively suppress high-frequency harmonics generated by the inverter.
- EMC filter ungrounded design effectively reduces leakage current to ground

### Comprehensive protection functions

- The entire series supports multiple protections against overvoltage, undervoltage, overcurrent, phase loss, overspeed, locked-motor, overload, motor temperature, short circuit to ground, etc
- Based on the severity of the type of fault, the inverter can be set to report alarm, shut down or continue running, which makes daily maintenance more convenient

## Excellent Performance

### Advanced motor drive technology

- Supports both asynchronous and synchronous motors to achieve high-performance current vector control
- Supports switchover between two groups of motor parameters
- Supports speed and torque mode control of motors

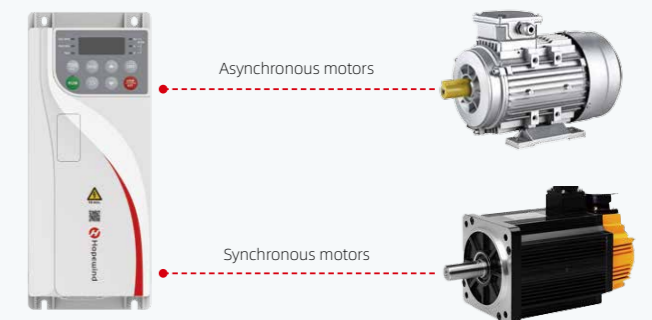

## Excellent Performance

### Extensive auto-tuning function

- Accurate auto-tuning ability of motor parameters: improves motor control accuracy and response speed
- Comprehensive auto-tuning modes: support motor auto-tuning needs in different scenarios

### Complete braking function

- Supports DC braking at startup/stop
- Supports overexcitation function which can effectively suppress the rise of bus voltage during deceleration, thereby avoiding frequent overvoltage faults
- The entire series can be configured with a built-in brake unit, saving installation space and electrical costs

### Powerful overload capacity

- High overload capacity can meet the need for long-term reliable operation under extreme load conditions
- Low overload: 110% of  $I_L$  for 60s or 150% of  $I_L$  for 10s in a duty cycle
- High overload: 150% of  $I_H$  for 60s or 200% of  $I_H$  for 10s in a duty cycle

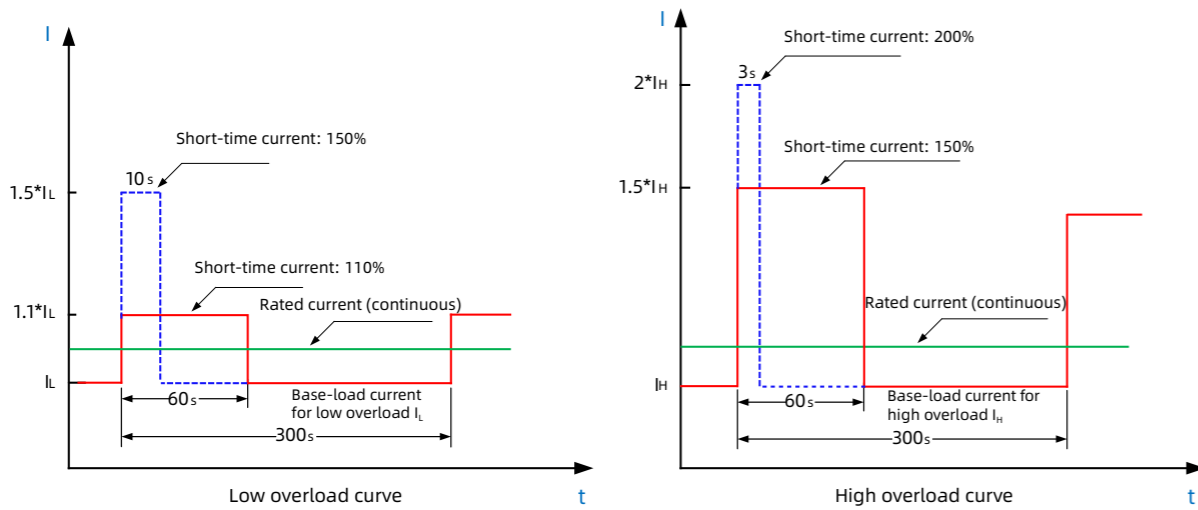

## Extensive Functionality

### High frequency output

- Output up to 1,500 Hz, suitable for high-frequency, high-speed motors

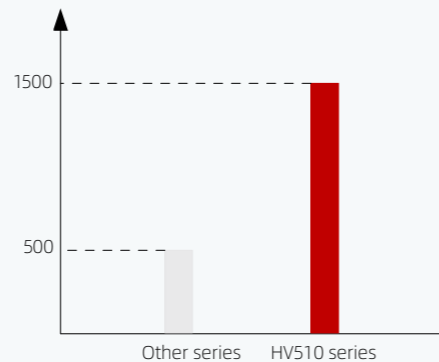

## Extensive Functionality

### Diversified expansion functions

- Communication card: supports major communication protocols, including Profibus-DP, Profinet IO, CANopen, Modbus TCP/IP, Ethercat, and EtherNet/IP
- Encoder card: supports the wiring of the incremental encoder and resolver
- I/O terminal card: provides more terminal functions
- External keypad: makes debugging easier and simpler

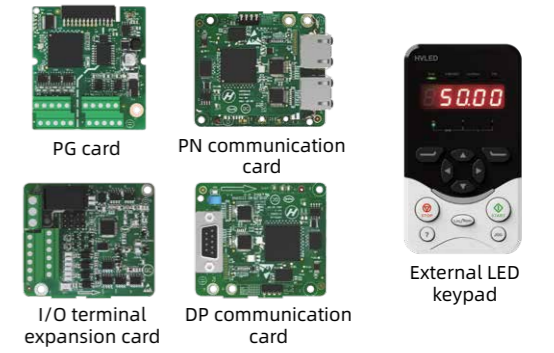

Note: The optional I/O terminal expansion card and the communication expansion card share the same expansion card slot, and cannot be installed and used at the same time.

### Background quick debugging software

- Supports inverter event recording and virtual oscilloscope function
- Supports parameter editing and status monitoring, to facilitate debugging and maintenance

▼ Parameter interface

▼ Fault record

### Special application software functions

- Master-slave control: suitable for master-slave synchronous control between two or more motors
- Simple PLC: supports cyclic operation of up to 16 segments with fixed time and speed
- PID: suitable for closed-loop systems for process control such as constant temperature, constant pressure, tension, etc
- Virtual I/O: easy internal logic control by means of simple settings
- Restart upon power failure: The inverter resumes operation automatically when power is restored after failure
- Multi-motor switchover: Two groups of motor parameters can be stored to enable switchover
- Position lock: Zero-speed hovering can be achieved under CLVC mode
- The wobble function is applicable to textile and chemical fiber processing equipment, which can improve the quality of spindle winding
- Random PWM depth: mitigates the harsh motor noise
- Encoder running in redundancy: automatic switching to OLVC mode in event of encoder failure under CLVC mode

Rated voltage: three phases 380 Vac/50 Hz					
Model	Heavy Load		Light Load		Frame Type
	Rated Power (kW)	Rated output current (A)	Rated power (kW)	Rated output current (A)	
HV510-A04T00007B	0.75	2.5	1.5	4.2	FA
HV510-A04T00015B	1.5	4.2	2.2	5.8	
HV510-A04T00022B	2.2	5.8	-	-	
HV510-A04T00040B	4	9.5	5.5	13	FB
HV510-A04T00055B	5.5	13	-	-	
HV510-A04T00075B	7.5	17	11	25	FC
HV510-A04T00110B	11	25	-	-	
HV510-A04T00150B	15	32	18.5	38	FD
HV510-A04T00185B	18.5	38	22	46	
HV510-A04T00220B	22	46	-	-	
HV510-A04T00300(B)	30	60	37	75	FE
HV510-A04T00370(B)	37	75	45	91	
HV510-A04T00450(B)	45	91	55	125	
HV510-A04T00550(B)	55	125	75	150	FF
HV510-A04T00750(B)	75	150	90	180	
HV510-A04T00900(B)	90	180	110	210	FG
HV510-A04T01100(B)	110	210	132	250	

Note: 1. Standard FA-FD frame models come with a built-in brake unit. To configure a brake unit for models from FE onwards, add "B" at the end of the model, such as "HV510-A04T00300B".

2. For all models, connection of DC reactors is not supported. Users can install their own AC input reactor as needed.

3. 150% cyclic overload is allowed under heavy load rated working conditions; 110% cyclic overload is allowed under light load rated working conditions. The overload cycle is 1 minute per every 5 minutes.

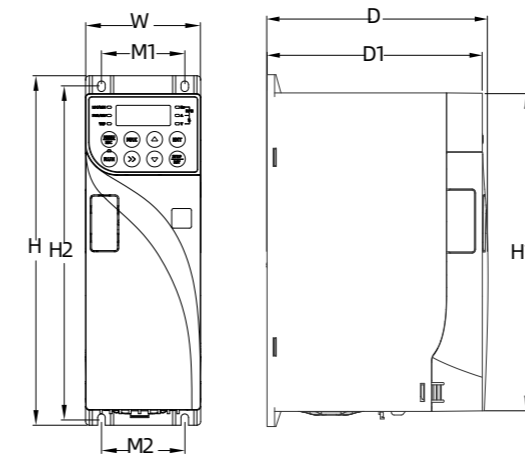

FA structure and installation dimensions

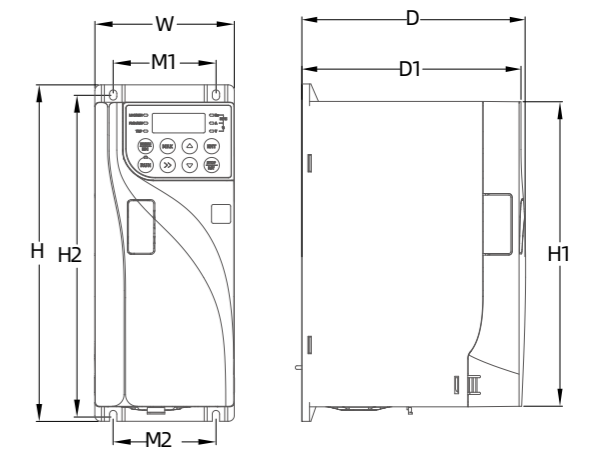

FB structure and installation dimensions

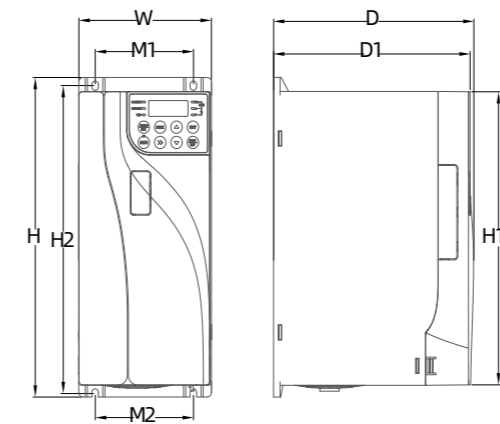

FC structure and installation dimensions

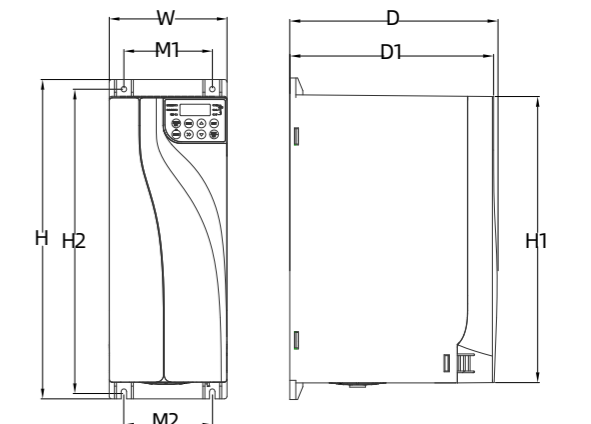

FD structure and installation dimensions

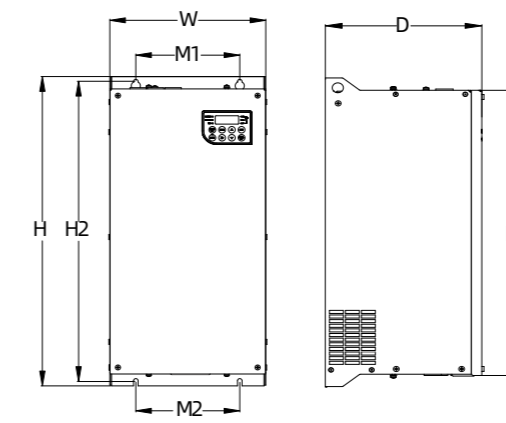

FE FF structure and installation dimensions

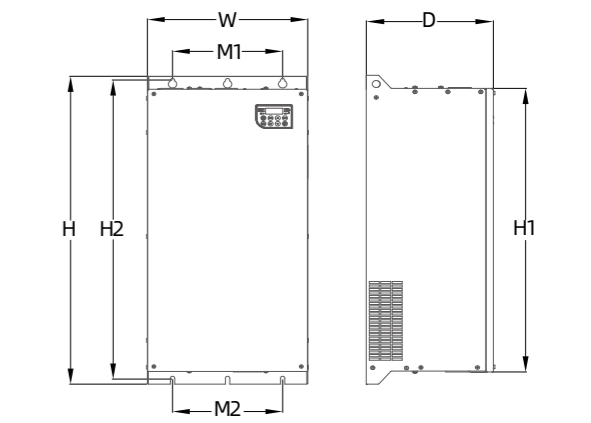

FG structure and installation dimensions

## Product Dimensions

Frame	Width (mm)	Height (mm)	Depth (mm)	Mounting Hole Horizontal Spacing M1 (mm)	Mounting Hole Horizontal Spacing M2(mm)	Mounting Hole Vertical Spacing H2 (mm)	Mounting Hole DiameterΦ (mm)	Net Weight(kg)
FA	76	232	175.5	55	55	221	5	1.7
FB	95	232	175.5	70	70	221	5	1.8
FC	121.5	272	187	90	90	262	6	3.3
FD	140	377	237	105	105	357	6.5	5.5
FE	240	500	225	160	160	485	7	16
FF	270	615	240	200	200	594	9	24
FG	335	712	255	230	230	688	9	38

## Recommended AC Reactor Selection

Model	AC Input Reactor		AC Output Reactor	
	Inductance (mH)	Current (A)	Inductance (mH)	Current (A)
HV510-A04T00007B	8	5	2	5
HV510-A04T00015B	4	7	1.6	6
HV510-A04T00022B	3	12	1.2	10
HV510-A04T00040B	1.5	16	0.7	14
HV510-A04T00055B	1.2	20	0.5	18
HV510-A04T00075B	0.8	32	0.4	26
HV510-A04T00110B	0.6	45	0.25	32
HV510-A04T00150B	0.4	55	0.2	40
HV510-A04T00185B	0.35	65	0.18	48
HV510-A04T00220B	0.3	80	0.15	60
HV510-A04T00300(B)	0.2	100	0.11	75
HV510-A04T00370(B)	0.18	120	0.09	95
HV510-A04T00450(B)	0.15	145	0.07	130
HV510-A04T00550(B)	0.11	200	0.055	160
HV510-A04T00750(B)	0.09	220	0.04	190
HV510-A04T00900(B)	0.07	275	0.035	220
HV510-A04T01100(B)	0.06	330	0.03	260

## Recommended Braking Resistor Selection

Inverter model Indicators	Minimum braking resistance (Ω)	Maximum braking current (A)	Recommended resistance R (Ω) power P	Braking unit	
HV510-A04T00007B	120	7	750Ω/150W	Built-in (standard)	
HV510-A04T00015B	80	10.5	350Ω/320W		
HV510-A04T00022B	80	10.5	250Ω/450W		
HV510-A04T00040B	47	17.5	150Ω/750W		
HV510-A04T00055B	29.6	28	150Ω/750W		
HV510-A04T00075B	29.6	28	100Ω/1125W		
HV510-A04T00110B	29.6	28	100Ω/1125W		
HV510-A04T00150B	29.6	28	30Ω/3750W		
HV510-A04T00185B	29.6	28	30Ω/3750W		
HV510-A04T00220B	24	35	30Ω/3750W		
HV510-A04T00300(B)	24	35	25Ω/4500W		Built-in (optional)
HV510-A04T00370(B)	16	52.5	25Ω/4500W		
HV510-A04T00450(B)	16	52.5	25Ω/4500W		
HV510-A04T00550(B)	8	105	10Ω/14000W		
HV510-A04T00750(B)	8	105	10Ω/14000W		
HV510-A04T00900(B)	5.6	157	6Ω/21000W		
HV510-A04T01100(B)	5.6	157	6Ω/21000W		

## Optional Accessories

Model	Accessory Name	Function and Use
HVLED	External LED keypad (with mounting base)	Supports parameter setting, viewing, and copying
HVCOM-USB	Communication adapter	Enables high-speed communication between hopelnsight (the background quick debugging software of the inverter) and a computer
HVIO-01	I/O terminal expansion card	Supports 3 DI input channels, 1 DO output channel, 1 AI input channel (-10 V-10 V), 2 AO output channels (0-10 V/0-20 mA), 1 temperature sampling channel (PT100, PT1000, KTY84), and 1 relay output channel
HVPG-ABZ-01	Incremental encoder expansion card	Supports the wiring of the ABZ incremental encoder
HVPG-ROT	Resolver expansion card	Supports the wiring of the resolver
HVCOM-DP-H	Profibus-DP communication card	Support Profibus-DP bus communication
HVCOM-PN-H	Profinet communication card	Supports Profinet IO bus communication
HVCOM-CA	CANopen communication card	Supports CANopen bus communication
HVCOM-TP-H	Modbus TCP/IP communication card	Supports Modbus TCP/IP communication
HVCOM-EC-H	EtherCAT communication card	Supports EtherCAT communication
HVCOM-EN-H	EtherNet/IP communication card	Supports EtherNet/IP communication



Office Address: Building 11, Second Industrial Zone, Guanlong Village, Xili Street, Nanshan District, Shenzhen, P.R.China  
Postal Code: 518055  
Customer Service Hotline: 400-8828-705  
Phone: +86-755-86026786  
Website: [www.hopewind.com](http://www.hopewind.com)

©2024 Hopewind Electric Co., Ltd.  
All rights reserved. V4.0.3

