

HOPEWIND

Stock Code: SSE-603063



Wind Power Generation System

Product Catalog



禾望电气
Hopewind

Company Profile 04
.....

Wind Power Products 06
.....

Overview of Wind Power Converters
Doubly-Fed Converters
Full-Power Converters
.....

Supporting Products 30
.....

Pitch Control System
Mobile Test Platform-Multi-Functional Power
Grid Simulator
.....

Remote O&M Products 40
.....

hopeView Network Monitoring System
Special Functions
.....

Typical Cases 46
.....

About Hopewind

01 Renewable Energy Field

Products cover 750kW~30MW wind power converters, 3kW~3.125MW PV inverters and 1.0MW~6.25MW inverter-transformer integrated containers.



02 Energy Storage Field

50kW~3.45MW energy storage converters, 5kW~12kW residential storage inverters, 1MW~6.9MW PCS combo as well as EMS, offgrid controllers and other equipment, which are widely used in power generation side, grid side, user side, microgrid and so on.



03 Hydrogen Energy

500kW~20MW IGBT hydrogen production power supply and hydrogen production intelligent management system and other equipment, which can be applied to grid-connected and offgrid renewable hydrogen production.



04 Power Quality Field

Provide 30kvar~140Mvar SVG products, which have been widely used in regional grids, wind power, photovoltaics, petrochemicals, coal, steel, oil fields and rail transit and other fields and industries.



05 Electric Drive Field

Provide a complete set of 0.75kW~22.4MW low-voltage and 8MVA~136MVA medium-voltage variable frequency drive solutions, widely used in metallurgy, petroleum and petrochemical, mining machinery, port cranes, distributed energy power generation, large-scale test platforms, marine equipment, textiles, chemicals, cement, municipal and other various industrial applications.

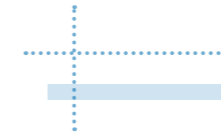

Shenzhen Hopewind Electric Co., Ltd. (Stock Code: 603063) focuses on the R&D, manufacturing, sales and services of renewable energy & electric drive products, with main products of wind power generation products, photovoltaic generation products, energy storage products, power quality products and electric drive products. Furthermore, Hopewind owns integrated independent R&D and testing platforms of high-power power electronic equipment and monitoring system.

Through innovation in technology and service, Hopewind continuously creates value for customers, and has become one of China's most competitive enterprises in the renewable energy field.



5 R&D and manufacturing bases
Shenzhen, Suzhou, Xi'an, Heyuan, Wuhan

30+ global service bases
Deployed worldwide to provide comprehensive services for global customers

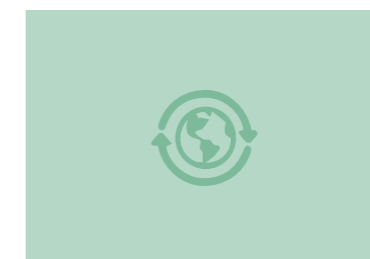

Wind Power Products

Overview of Wind Power Converters

Doubly-Fed Converters

Full-Power Converters

Product Overview

Wind energy is a clean and renewable energy source. As the most important form of utilizing wind energy, wind power generation has good environmental and economic benefits.

In wind power generator systems, a wind power converter can realize variable-speed constant-frequency control of the wind turbine, by converting the turbine electric energy with variable frequency and amplitude into constant voltage and constant frequency (CVCF) through AC-DC-AC conversion. Wind power converters can be classified into doubly-fed converters and full-power converters. Doubly-fed converters match with DFIG and full power converters match with PMSG/EEIG/SCIG.

Name	Voltage	Power	Cooling Mode	Applicable Model	Application Environment
Doubly-fed Converters	690V	1.5MW~6.XMW	Air Cooling	Doubly-fed Induction Generator	Standard Type Plateau Type Low Temperature Type Coastal Type Offshore Type
		2.0MW~6.XMW	Liquid Cooling		
	950V / 1140V	3.0MW~12.0MW	Air Cooling		
		5.0MW~20.0MW	Liquid Cooling		
Full-power Converters	690V	1.0MW~12.0MW	Liquid Cooling	Direct-drive Permanent Magnet Generator Medium / High-speed Permanent Magnet Generator Electric Excitation Generator Squirrel-cage Induction Generator	
	900V / 950V / 1140V	3.XMW~30.0MW			
	3300V	5.0MW~25.0MW			



690V Doubly-Fed Converter

Hopewind **HWDF069 Series Doubly-fed Converters** are mainly used together with doubly-fed generators in the wind power generation system, to obtain the optimum power generation efficiency and power quality. When the generator speed changes with the wind speed, the converter alters the magnetic field of the rotor by controlling the rotor's excitation so that the frequency, phase, and amplitude of the generator's output voltage are consistent with those of the grid, thereby achieving variable-speed constant-frequency power generation for the wind power generation system. In addition, the converter can adjust the frequency, active power, and reactive power of the generator by changing the frequency, amplitude, and phase of the rotor's excitation current.



Hopewind utilizes multiple patented technologies to provide doubly-fed wind power converters in a range of specifications, featuring a rated voltage of 690V and a rated frequency of 50Hz/60Hz. Hopewind owns complete independent intellectual property rights over these products.

- 1 Power Range**
1.5MW, 2.0MW, 2.5MW
3.2MW, 3.6MW, 4.2MW
5.6MW, 6.25MW
- 2 Cooling Mode**
Air Cooling
Liquid Cooling
- 3 Application Environment**
Standard Type, Plateau Type
Low Temperature Type,
Coastal Type

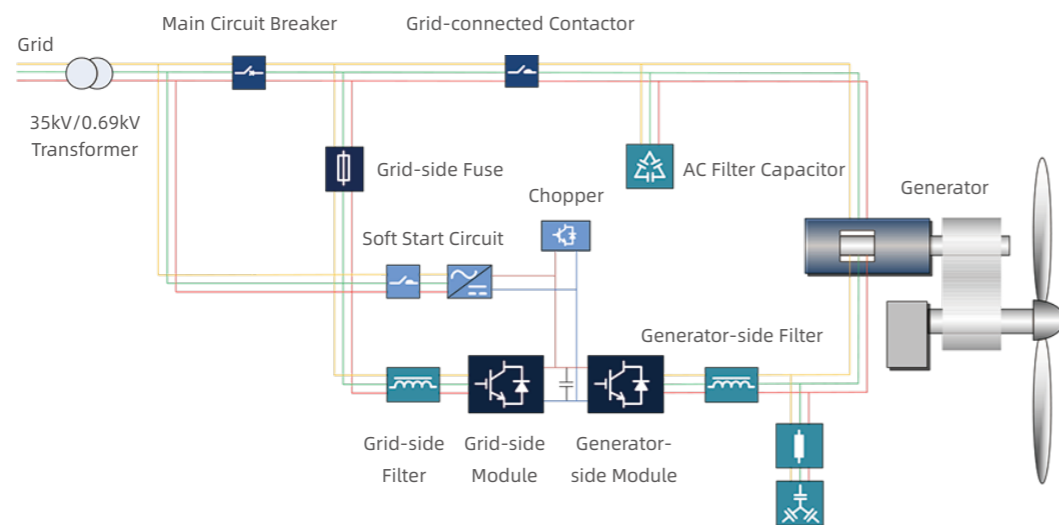

Topology of 690V Doubly-fed Wind Power Generation System

Hopewind



690V Air-Cooled Doubly-Fed Converter



Performance Characteristics

● High Power Density

The power density is raised by 30%, improving turbine design flexibility.

● Good Compatibility

Catering to market needs, the product supports the derivative integration with the master control unit and with the turbine auxiliary transformer.

● Standardization of Parts

Key components of the whole series of converters, such as grid-connected contactors and fans, are standardized to reduce parts categories.

● Optimized Heat Dissipation Design

The optimized heat dissipation layout inside the cabinet, together with external fans, enhances the converter's environmental adaptability.

● Higher Efficiency

The filter design is optimized to reduce the grid-side excitation current and the rotor's excitation current, thereby lowering converter losses.

● Remote Monitoring and Intelligent Diagnosis

The remote network system of the converter can intelligently diagnose wind turbine faults.

Technical Specifications

Parameters	Power	1.5MW	2.0MW	2.5MW	3.0MW	3.6MW	4.5MW	5.6MW	6.25MW
Operating Voltage	552V~759V ^①								
Rated Current	1527A	2036A	2545A	3083A	3670A	4600A	5676A	6312A	
Grid-side Frequency	47.5Hz~52.5Hz / 57Hz~63Hz ^②								
Grid-side Maximum Continuous Current	305A	420A	550A	650A	750A	1250A	1500A	1500A	
Grid-side Overload Current (1min/10min)	336A	462A	605A	715A	825A	1375A	1650A	1650A	
Generator-side Frequency	0Hz~20Hz								
Generator-side Maximum Continuous Current	580A	800A	1000A	1100A	1250A	1400A	1800A	2000A	
Generator-side Overload Current (1min/10min)	638A	880A	1100A	1210A	1375A	1540A	1980A	2200A	
Grid Voltage Harmonic Tolerance	≤5%								
Grid Voltage Imbalance Tolerance	≤8%								
System Efficiency	≥97%								
Noise	<82dB								
Operating Temperature	-40°C to +50°C (45°C to 50°C derated)								
Storage Temperature	-40°C to +70°C								
Altitude	Standard Type: ≤3000m; Plateau Type: 3000m~5000m ^③								
Cooling Mode	Air Cooling								
Ingress Protection	IP23								
Fault voltage ride through (FVRT)	In compliance with the Wind Turbines -test Procedure of Voltage Fault Ride Through Capability								
Dimensions (W*H*D) (mm)	2000*2000*600				3000*2000*600				

① The product is capable of running at 1.3 times the high voltage.

② For other frequencies, consult Hopewind.

③ For solutions applicable to an altitude higher than 4000m, consult Hopewind.

* ①②③ are applicable to the whole doubly-fed converter series.

690V Liquid-Cooled Doubly-Fed Converter

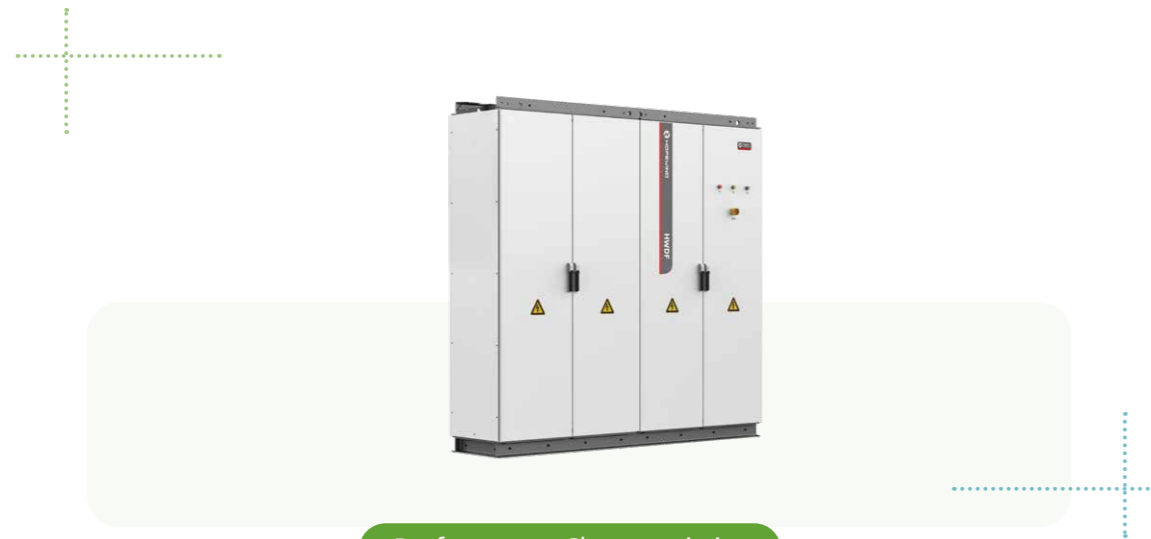

Performance Characteristics

● High Power Density

The maximum unit power is up to 6.XMW and the power density is raised by 100%.

● High Reliability Design

The product's high IP rating makes it particularly suitable for highly saline and misty, polluted, and humid environments.

● Flexible Layout

The block-style design supports flexible arrangement and facilitates the expansion into one converter unit integrated with master control unit/liquid cooler.

● Lightweight Parts

A single power module weighs 11kg, and the maximum weight of wearing parts does not exceed 20kg, making it convenient for one-person maintenance.

● Customized Inlet and Outlet

The cable entry of the grid, stator, and rotor can be customized to meet diverse requirements of the tower base and nacelle.

● Remote Monitoring and Intelligent Diagnosis

The remote network system of the converter can intelligently diagnose wind turbine faults.

Technical Specifications

Parameters	Power	2.0MW	2.5MW	3.2MW	4.2MW	5.0MW	6.25MW
Operating Voltage		552V~759V					
Rated Current		2036A	2545A	3279A	4257A	5089A	6312A
Grid-side Frequency		47.5Hz~52.5Hz / 57Hz~63Hz					
Grid-side Maximum Continuous Current		420A	550A	700A	1250A	1250A	1500A
Grid-side Overload Current (1min/10min)		462A	605A	770A	1375A	1375A	1650A
Generator-side Frequency		0Hz~20Hz					
Generator-side Maximum Continuous Current		800A	1000A	1250A	1400A	1600A	2000A
Generator-side Overload Current (1min/10min)		880A	1100A	1375A	1540A	1760A	2200A
Grid Voltage Harmonic Tolerance		≤5%					
Grid Voltage Imbalance Tolerance		≤8%					
System Efficiency		≥97%					
Noise		<70dB					
Operating Temperature		Ambient Temperature: -40 C to +50 C; Liquid Inlet Temperature: +5 C to +55 C (50 C to 55 C derated)					
Storage Temperature		-40°C to +70°C					
Altitude		Standard Type: ≤3000m; Plateau Type: 3000m~5000m					
Cooling Mode		Liquid Cooling					
Ingress Protection		IP54					
Fault Voltage Ride Through (FVRT)		In compliance with the Wind Turbines-test Procedure of Voltage Fault Ride Through Capability					
Dimensions (W*H*D) (mm)		2300*2200*650				2400*2200*600	

950V/1140V Doubly-fed Converter

Hopewind **Low-voltage Three-level Doubly-fed Converter** is used in combination with the 950V/1140V doubly-fed generator in the wind power generation system. It adopts the type-i three-level topology, with a system voltage level of 950V/1140V, and the core power electronic devices are IGBTs.

When the generator speed changes with the wind speed, the converter alters the magnetic field of the rotor by controlling the rotor's excitation so that the frequency, phase, and amplitude of the generator's output voltage are consistent with those of the grid, thereby achieving variable-speed constant-frequency power generation for the wind power generation system. In addition, the converter can adjust the frequency, active power, and reactive power of the generator by changing the frequency, amplitude, and phase of the rotor's excitation current.



Hopewind utilizes multiple patented technologies to provide doubly-fed wind power converters in a range of specifications, featuring a rated voltage of 950V/1140V and a rated frequency of 50Hz/60Hz. Hopewind owns complete independent intellectual property rights over these products.

- 1 Power Range**
3.XMW~20.0MW
- 2 Cooling Mode**
Air Cooling
Liquid Cooling
- 3 Application Environment**
Standard Type,
Plateau Type
Low Temperature Type,
Coastal Type
Offshore Type
- 4 Stator Voltage**
The stator voltage range can be raised, for example, the medium voltage solution is available for the stator.

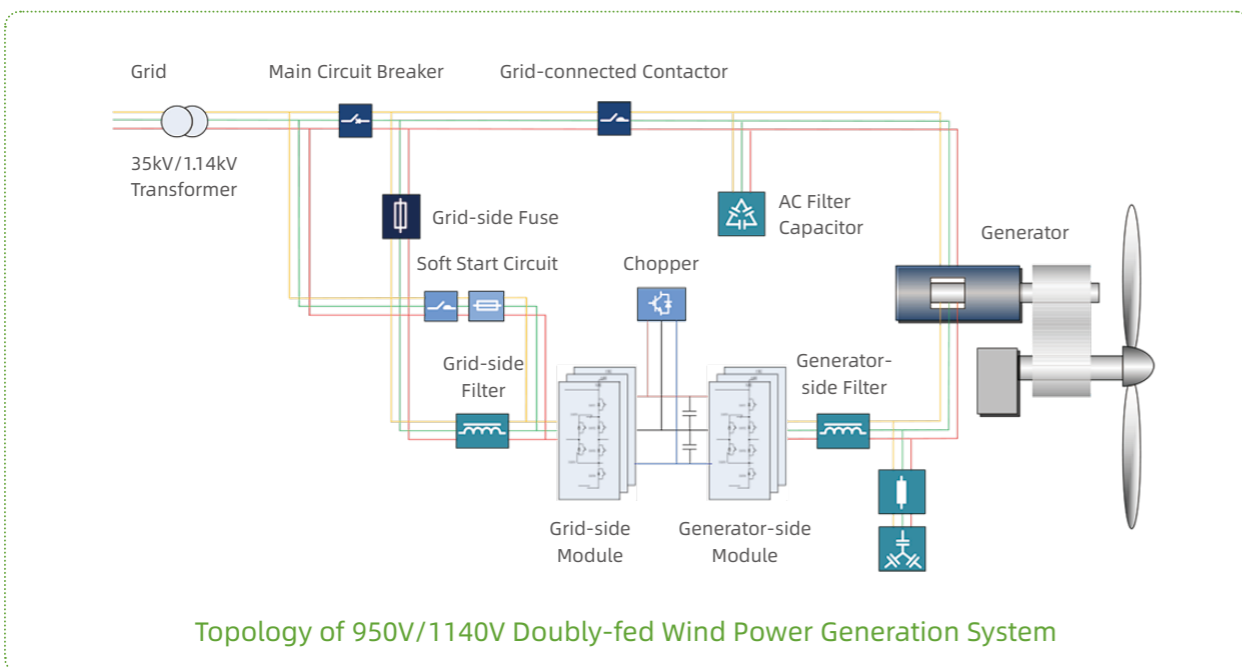

Hopewind

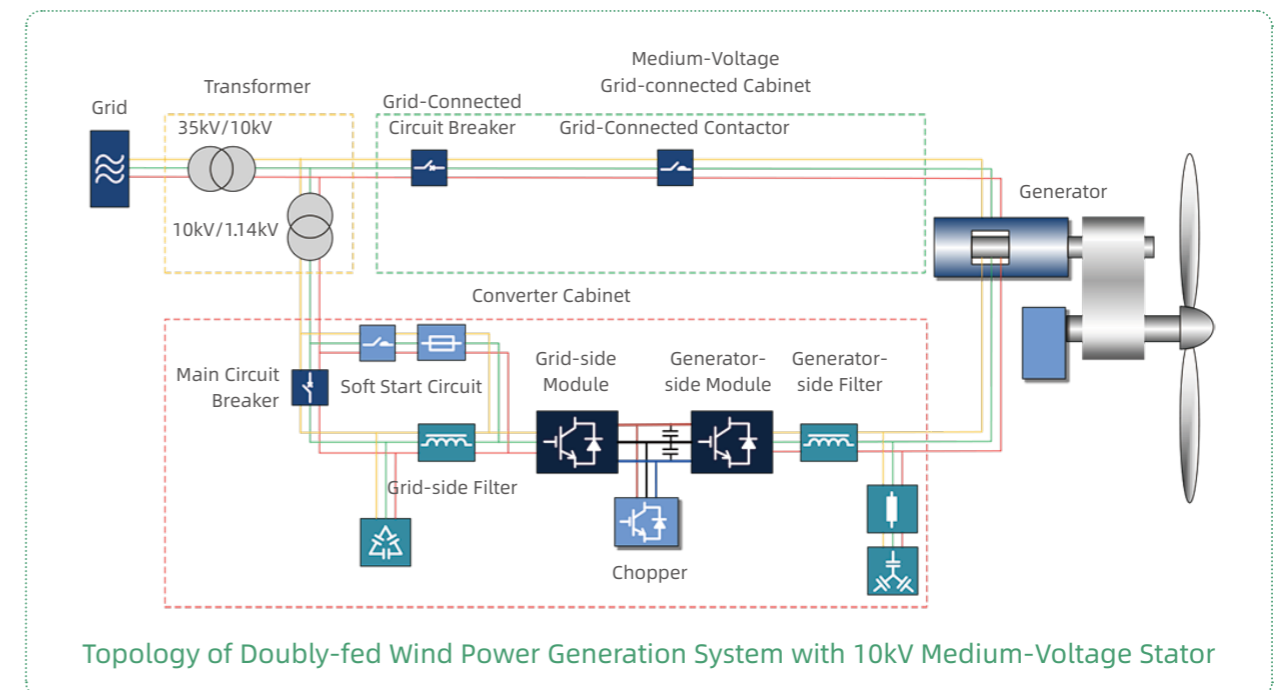

950V/1140V Air-Cooled Doubly-Fed Converter



Performance Characteristics

● Mature Design

Hopewind has over 10 years of experience in the development and application of three-level systems, along with a mature supply chain. The product shares many similarities with the 690V system.

● Platform-Based Design

The product is built on the 690V system platform, featuring a uniform structural layout and cabling design. This ensures a seamless transition in turbine upgrading design.

● Excellent Power Quality

The converter uses a three-level topology solution, with more output levels and lower harmonic content.

● Lower Converter Losses

Reduced current caused by voltage decreases the heat of the converter, alleviating the cooling pressure of the tower.

● Better Cost-Effectiveness

With generator power design bottlenecks addressed and internal cable usage reduced within the turbine, the overall cost of the turbine system is lowered.

● Remote Monitoring and Intelligent Diagnosis

The remote network system of the converter can intelligently diagnose wind turbine faults.

Technical Specifications

Parameters	Power	3.XMW	4.XMW	5.XMW	6.XMW	7.XMW	8.XMW	10.0MW	12.0MW
Operating Voltage	855V~1045V	1026V~1254V							
Rated Current	2950A	2460A	2962A	3436A	3821A	4620A	5212A	6100A	7286A
Grid-side Frequency	47.5Hz~52.5Hz / 57Hz~63Hz								
Grid-side Maximum Continuous Current	515A	480A	480A	600A	600A	700A	800A	900A	1000A
Grid-side Overload Current (1min/10min)	567A	528A	528A	660A	660A	770A	880A	990A	1100A
Generator-side Frequency	0Hz~20Hz								
Generator-side Maximum Continuous Current	900A	650A	1000A	1100A	1200A	1400A	1600A	1800A	2000A
Generator-side Overload Current (1min/10min)	990A	715A	1100A	1210A	1320A	1540A	1760A	1980A	2200A
Grid Voltage Harmonic Tolerance	≤5%								
Grid Voltage Imbalance Tolerance	≤8%								
System Efficiency	≥98%								
Noise	<82dB								
Operating Temperature	-40°C to +50°C (45°C to 50°C derated)								
Storage Temperature	-40°C to +70°C								
Altitude	Standard Type: ≤3000m; Plateau Type: 3000m~5000m								
Cooling Mode	Air Cooling								
Ingress Protection	IP23								
Fault Voltage Ride Through (FVRT)	In compliance with the Wind Turbines-test Procedure of Voltage Fault Ride Through Capability								
Dimensions (W*H*D) (mm) ^①	2000*2000*600	2700*2000*600 2000*2200*700	2800*2000*600 2000*2200*700	3000*2000*600 2000*2200*700	4200*2000*600 3000*2200*700				

① For dimensions of the doubly-fed converter with the medium-voltage stator, consult Hopewind.

950V/1140V Liquid-Cooled Doubly-fed Converter



Performance Characteristics

● High Reliability Design

The product's high IP rating makes it particularly suitable for highly saline and misty, polluted, and humid environments.

● Flexible Layout

The block-style design supports flexible arrangement and facilitates the expansion into one converter unit integrated with master control unit/liquid cooler.

● Easy to Maintain

Compact, modular, and lightweight core components reduce maintainers' workload.

● Customized Cable Entry

The cable entry of the grid, stator, and rotor can be customized to meet diverse requirements of the tower base and nacelle.

● Remote Monitoring and Intelligent Diagnosis

The remote network system of the converter can intelligently diagnose wind turbine faults.

Technical Specifications

Parameters	5.0MW~6.0MW	8.0MW~10.0MW	12.0MW~18.0MW	19.0MW~20.0MW
Operating Voltage	855V~1045V	1026V~1254V		
Rated Current	3696A~4407A	4917A~6100A	7404A~10959A	11551A~12143A
Grid-side Frequency	47.5Hz~52.5Hz / 57Hz~63Hz			
Grid-side Maximum Continuous Current	950A~1100A	700A~900A	1000A~1300A	1400A~1500A
Grid-side Overload Current (1min/10min)	1045A~1210A	770A~990A	1100A~1430A	1540A~1650A
Generator-side Frequency	0Hz~20Hz			
Generator-side Maximum Continuous Current	1000A~1250A	1500A~1800A	2000A~2600A	2800A~3000A
Generator-side Overload Current (1min/10min)	1100A~1375A	1650A~1980A	2200A~2860A	3080A~3300A
Grid Voltage Harmonic Tolerance	≤5%			
Grid Voltage Unbalance Tolerance	≤8%			
System Efficiency	≥98%			
Noise	<80dB			
Operating Temperature	Ambient Temperature: -30 C to +50 C; Liquid Inlet Temperature: +5 C to +55 C (50 C to 55 C derated)			
Storage Temperature	-40°C to +70°C			
Altitude	Standard Type: ≤3000m; Plateau Type: 3000m~5000m			
Cooling Mode	Liquid Cooling			
Ingress Protection	IP54			
Fault Voltage Ride Through (FVRT)	In compliance with the Wind Turbines-test Procedure of Voltage Fault Ride Through Capability			
Dimensions (W*H*D) (mm) ^①	2500*2000*600	2800*2200*650	4500*2200*650	5000*2200*650

① For dimensions of the doubly-fed converter with the medium-voltage stator, consult Hopewind.

950V/1140V
Doubly-fed

690V Full-Power Converter

Hopewind **HWFP069 Series Full-power Converters** are used in combination with permanent magnet synchronous generators, electric excitation synchronous generators, or squirrel-cage induction generators in the wind power generation system. The converter consists of a generator-side converter and a grid-side converter, which are connected by a DC bus. The generator-side converter connects to the stator of the generator to achieve variable-speed constant-frequency control of the generator, ensuring optimal power generation efficiency. It also transfers power to the grid-side converter through DC bus. The grid-side converter connects to the grid. It provides high-quality power to the grid as well as balancing the voltages on both sides of the DC bus. The full-power converter enables grid connection with zero impact and boasts superior fault voltage ride-through capability, realizing friendly grid-connected wind turbine matching with the generator. In addition, the grid-side converter has excellent active power, reactive power, and voltage regulation capabilities.



Hopewind utilizes multiple patented technologies to provide full-power wind power converters in a range of specifications, featuring a rated voltage of 690V and a rated frequency of 50Hz/60Hz. Hopewind owns complete independent intellectual property rights over these products.

1 Power Range
1.0MW~12.0MW

2 Cooling Mode
Liquid Cooling

3 Application Environment
Standard Type, Plateau Type
Low Temperature Type,
Coastal Type
Sea-based Type

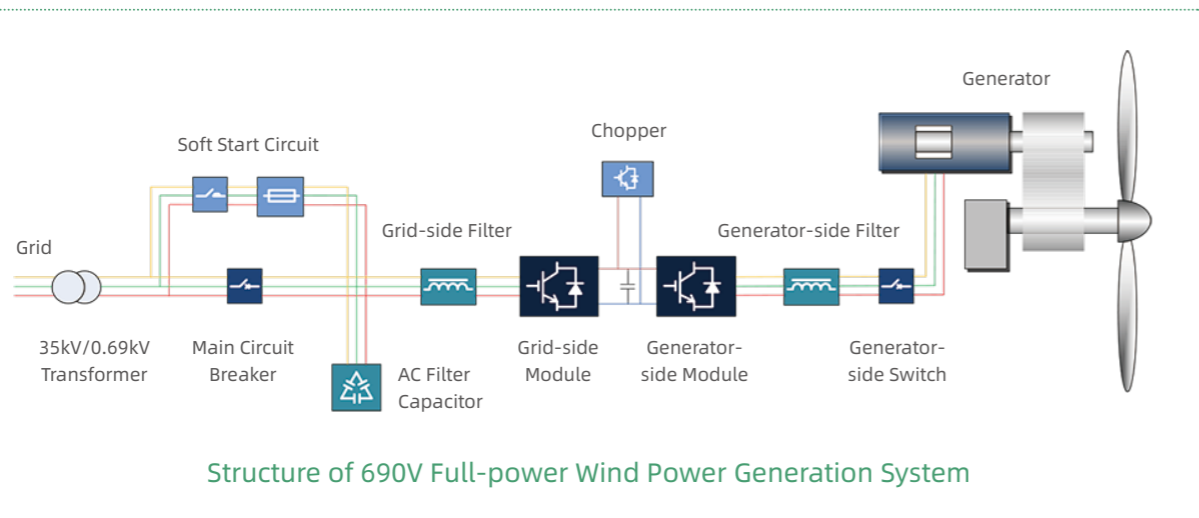

Hopewind



690V Full-Power Converter

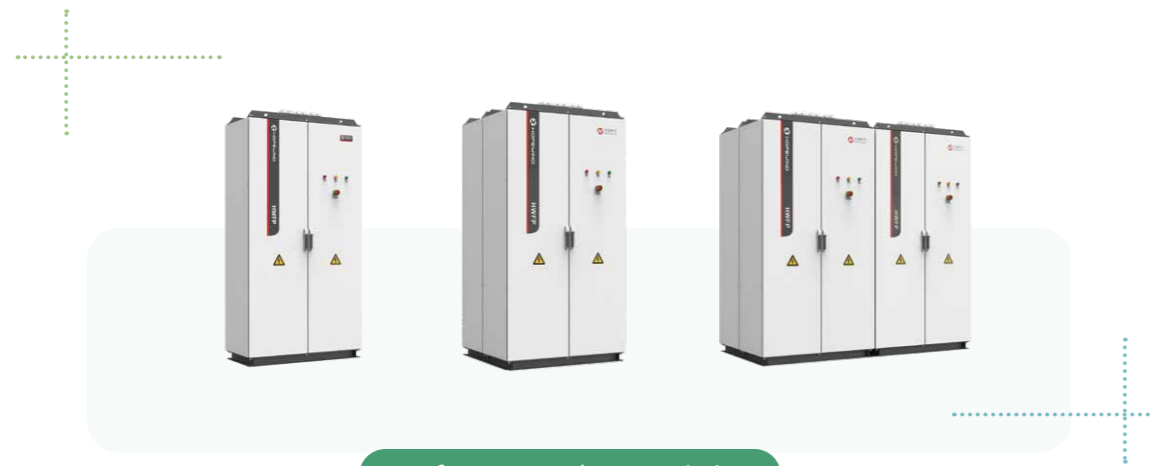

Performance Characteristics

● High Power Density

A new-generation power layout pattern is adopted, raising power density by 100%.

● System Fault Redundancy

Faulty modular converters can be removed online, minimizing power generation losses caused by converter faults.

● System Design Redundancy

When multiple high-power modular converters are paralleled, one modular converter serves as a backup and is ready to replace a faulty converter at any time.

● Control System Redundancy

The innovative control system architecture, configured with dual control systems, achieves online redundancy backup for the control system.

● Low-Power Switch-in

Different numbers of modular converters are used for different power ranges of the turbine to improve converter efficiency at low power.

● Special Design for Offshore Applications

Rich experience in offshore applications, with well-designed protection against corrosion, moisture, condensation, and mildew.

● Energy-saving Standby Mode

The energy-saving standby mode reduces losses during standby periods for both the converter and liquid cooling system, enhancing the owner's power generation revenue.

● Remote Monitoring and Intelligent Diagnosis

The remote network system of the converter can intelligently diagnose wind turbine faults.

Technical Specifications

Parameters	Power	1.0MW	1.5MW	1.6MW	2.0MW~3.2MW	3.3MW~4.5MW	4.6MW~6.0MW	6.0MW~8.0MW	12.0MW
Operating Voltage		552V~759V ^①							
Grid-side Frequency		47.5Hz~52.5Hz / 57Hz~63Hz ^②							
Grid-side Maximum Continuous Current		1000A	1500A	1600A					
Grid-side Overload Current (1min/10min)		1100A	1650A	1760A					
Generator-side Frequency		1Hz~100Hz ^③							
Generator-side Maximum Continuous Current		1000A	1500A	1600A					
Generator-side Overload Current (1min/10min)		1100A	1650A	1760A					
Grid Voltage Harmonic Tolerance		≤5%							
Grid Voltage Imbalance Tolerance		≤8%							
System Efficiency		≥97%							
Noise		<70dB							
Operating Temperature		Ambient Temperature: -30 C to +50 C; Liquid Inlet Temperature: +5 C to +55 C (50 C to 55 C derated)							
Storage Temperature		-40°C to +70°C							
Altitude		Standard Type: ≤3000m, Plateau Type: 3000m~5000m ^④							
Cooling Mode		Liquid Cooling							
Ingress Protection		IP54							
Fault Voltage Ride Through (FVRT)		In compliance with the Wind Turbines -test Procedure of Voltage Fault Ride Through Capability							
Dimensions (W*H*D) (mm)		1200*2200*600							

2 Connected in Parallel | 3 Connected in Parallel | 4 Connected in Parallel | 6 Connected in Parallel | 8 Connected in Parallel

① The product is capable of running at 1.3 times the high voltage.
 ② For other frequencies, consult Hopewind.
 ③ For solutions applicable to a frequency higher than 100Hz, consult Hopewind.
 ④ For solutions applicable to an altitude higher than 4000m, consult Hopewind.
 * ①②③④ are applicable to the whole converter series.

900V/950V/1140V Full-Power Converter

Hopewind **Low-Voltage Three-Level Full-Power Converter** is used in combination with the 900V/950V/1140V permanent magnet synchronous generator or squirrel-cage induction generators in the wind power generation system. It adopts the type-I three-level topology, with a system voltage level of 900V/ 950V/1140V, and core power conversion modules use IGBTs.

The converter consists of a generator-side converter and a grid-side converter, which are connected by a DC bus. The generator-side converter connects to the stator of the generator to achieve variable-speed constant-frequency control of the generator, ensuring optimal power generation efficiency. It also transfers power to the grid-side converter through DC bus. The grid-side converter connects to the grid. It provides high-quality power to the grid as well as balancing the voltages on both sides of the DC bus. The full-power converter enables grid connection with zero impact and boasts superior fault voltage ride-through capability, realizing friendly grid-connected wind turbine matching with the generator. In addition, the grid-side converter has excellent active power, reactive power, and voltage regulation capabilities.



Hopewind utilizes multiple patented technologies to provide full-power wind power converters in a range of specifications, featuring a rated voltage of 900V/950V/1140V and a rated frequency of 50Hz/60Hz. Hopewind owns complete independent intellectual property rights over these products.

1 Power Range
3.XMW~30.0MW

2 Cooling Mode
Liquid Cooling

3 Application Environment
Standard Type, Plateau Type
Low Temperature Type,
Coastal Type
Offshore Type

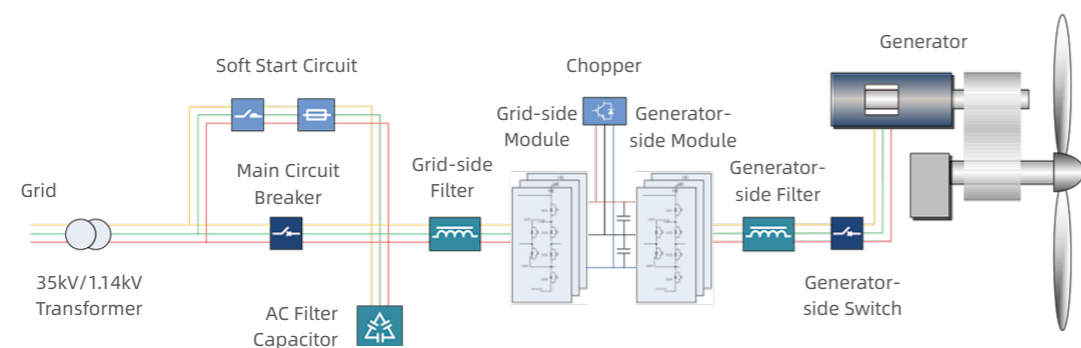

Topology of 900V/950V/1140V Full-Power Wind Power Generation System

Hopewind



900V/950V/1140V Full-Power Converter



Performance Characteristics

● Mature Design

Hopewind has over 10 years of experience in the development and application of three-level systems, along with a mature supply chain. The product shares many similarities with the 690V system.

● Excellent Power Quality

The converter uses a three-level topology solution, with more output levels and lower harmonic content.

● Higher Efficiency

The efficiency is as high as 98% under rated conditions, greatly increasing the turbine's power generation revenue.

● Better Cost-Effectiveness

With generator power design bottlenecks addressed and internal cable usage reduced within the turbine, the overall cost of the turbine system is lowered.

● Efficient O&M

Modular, lightweight, and standardized component design simplifies assembly and maintenance, reducing material and spare parts costs.

● Energy-saving Standby Mode

The energy-saving standby mode reduces losses during standby periods for both the converter and liquid cooling system, enhancing the owner's power generation revenue.

● Remote Monitoring and Intelligent Diagnosis

The remote network system of the converter can intelligently diagnose wind turbine faults.

Technical Specifications

Parameters	Power	1.5MW (Power Cabinet)	1.8MW (Power Cabinet)	2.2MW (Power Cabinet)	3.X~ 4.4MW	4.X~ 6.6MW	6.X~ 8.8MW	9.X~ 13.0MW	12.X~ 17.0MW	18.X~ 26.0MW	24.X~ 30.0MW
Operating Voltage	1026V~1254V										
Grid-side Frequency	47.5Hz~52.5Hz / 57Hz~63Hz										
Grid-side Maximum Continuous Current	900A	1060A	1300A								
Grid-side Overload Current (1min/10min)	990A	1166A	1430A								
Generator-side Frequency	1Hz~100Hz										
Generator-side Maximum Continuous Current	900A	1060A	1300A								
Generator-side Overload Current (1min/10min)	990A	1166A	1430A								
Grid Voltage Harmonic Tolerance	≤5%										
Grid Voltage Imbalance Tolerance	≤8%										
System Efficiency	≥98%										
Noise	<80dB										
Operating Temperature	Ambient Temperature: -30 C to +50 C; Liquid Inlet Temperature: +5 C to +55 C (50 C to 55 C derated)										
Storage Temperature	-40°C to +70°C										
Altitude	Standard Type: ≤3000m; Plateau Type: 3000m~5000m										
Cooling Mode	Liquid Cooling										
Ingress Protection	IP54										
Fault Voltage Ride Through (FVRT)	In compliance with the Wind Turbines -test Procedure of Voltage Fault Ride Through Capability										
Dimensions (W*H*D) (mm)	700*2200*650				Size A	Size B	Size C	Size D	2*Size C/ Size E	2*Size D	2*Size E

Hopewind power cabinets, distribution cabinets, and liquid cooling cabinets used in the low-voltage three-level full-power converter are all designed with standardized dimensions, allowing flexible layout combinations between cabinets.

The recommended dimensions for the 3.XMW~20.0MW converters are as follows:

Size A: 1400*2200*1300; Size B: 2100/1700*2200*1300; Size C: 2800/2400*2200*1300; Size D: 3500/3100*2200*1300; Size E: 4200*2200*1300

900V/950V/1140V Full-power

3300V Full-Power Converter

Hopewind HW8000 Three-Level Medium-Voltage Wind Power Converter

is used in combination with the medium-voltage permanent magnet synchronous generators in the wind power generation system. It adopts the diode-clamped three-level converter technology to provide a system voltage level of 3.3kV. The core power conversion modules use IGCTs.

The generator-side converter connects to the stator of the generator to achieve variable-speed constant-frequency control of the generator, ensuring optimal power generation efficiency. It also transfers power to the grid-side converter through DC bus. The grid-side converter connects to the grid. It provides high-quality power to the grid as well as balancing the voltages on both sides of the DC bus. The overall operation of the converters facilitates the electromagnetic torque control and magnetic field control of the generator, and achieves the conversion of wind energy into electrical energy.

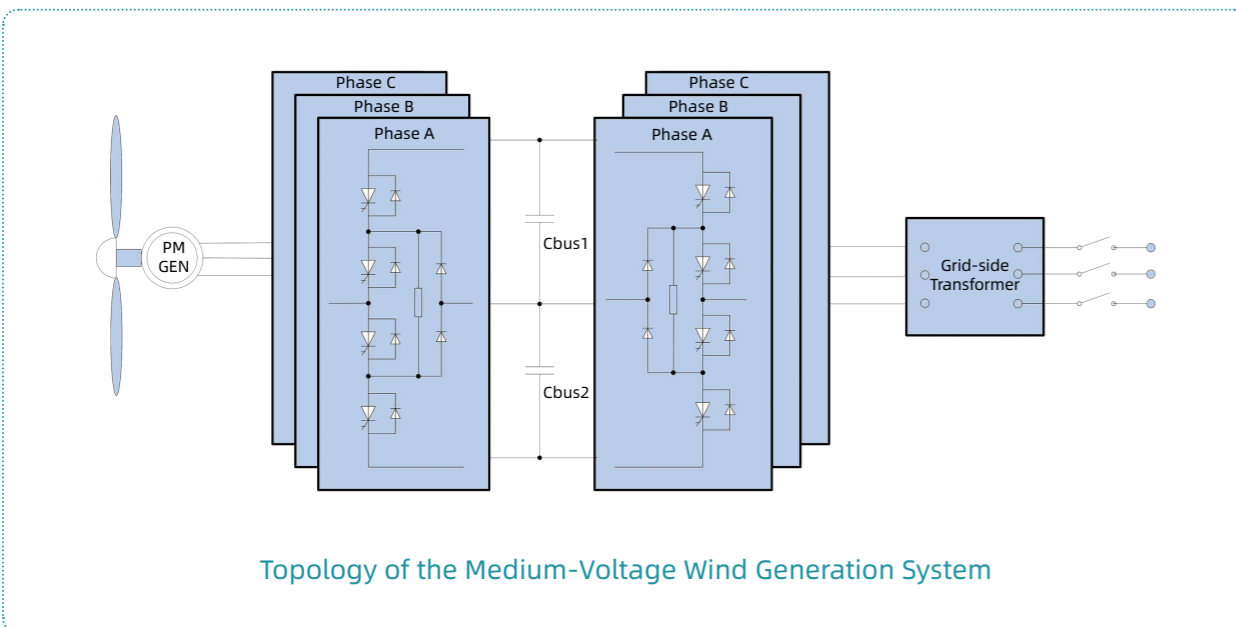

Topology of the Medium-Voltage Wind Generation System

Container-type Integrated Medium-Voltage Wind Power Converter

In offshore wind power applications, high humidity, high salt, and highly demanding maintenance challenge the wind turbine generator systems (WTGSs). A container structure can be adopted for the medium-voltage wind power converter used in offshore wind power generation systems, with the entire converter and its auxiliary equipment installed inside the container.

Performance Characteristics

- A standard container is used to standardize the outer platform design for the tower.
- It is deployed on the outer platform of the tower base to help optimize the tower design and costs.
- The reliable sealing, along with the converter's robust protection, ensures safe operation.
- Remote monitoring and intelligent diagnosis: The remote network system of the converter can intelligently diagnose wind turbine faults.



Technical Specifications

Parameters	Power	5.0MW	6.0MW	7.0MW	8.0MW	10.0MW	12.5MW
Grid-side Operating Voltage	3000V~3600V						
Grid-side Frequency	47.5Hz~52.5Hz / 57Hz~63Hz						
Grid-side Maximum Continuous Current	1112A	1334A	1556A	1750A	2022A	2426A	
Grid-side Overload Current (1min/10min)	1334A	1601A	1867A	2134A	2224A	2669A	
Generator-side Frequency	1Hz~100Hz						
Generator-side Maximum Continuous Current	1112A	1334A	1556A	1750A	2022A	2426A	
Generator-side Overload Current (1min/10min)	1334A	1601A	1867A	2134A	2224A	2669A	
Grid Voltage Harmonic Tolerance	≤5%						
Grid Voltage Imbalance Tolerance	≤8%						
System Efficiency	≥98%						
Noise	≤80dB						
Operating Temperature	Ambient Temperature: -30 C to +50 C; Liquid Inlet Temperature: +5 C to +55 C (50 C to 55 C derated)						
Storage Temperature	-40°C to +70°C						
Altitude	≤1000m						
Cooling Mode	Liquid Cooling						
Ingress Protection	IP54						
Fault Voltage Ride Through (FVRT)	In compliance with the Wind Turbines-test Procedure of Voltage Fault Ride Through Capability						
Dimensions (W*H*D) (mm)	3600*2200*2300						

Standard Cabinet-type Medium-Voltage Wind Power Converter

- The IGCT three-level topology design ensures higher efficiency, high power density, and low heat loss.
- IGCTs provide an overload capacity up to 150% and the short-term overload capacity is ten times more than that of IGBTs.
- IGCTs feature high reliability, crimp-on construction, and inherently low failure rate, eliminating the risk of "explosion".
- Modular design, block-style assembly, compact size, and light weight facilitate product disassembly and O&M.
- Liquid cooling, high power conversion efficiency, redundancy design of the cooling system, and deionized protection ensure reliable product operation for a longer time.
- The optimized notch filter design enhances the suppression of harmonics within a certain frequency domain, further improving the power quality.
- Container-type medium-voltage wind power converters can be equipped based on customer requirements, to provide better protection.
- Remote monitoring and intelligent diagnosis: The remote network system of the converter can intelligently diagnose wind turbine faults.



Supporting Products

Pitch Control System

Mobile Test Platform-multi-functional Power Grid Simulator

Pitch Control System

Based on PMD100, the system uses a tailored permanent magnet synchronous generator, supercapacitor module, or lithium battery module. Hopewind PMC pitch control system features a simple architecture, high safety and reliability, and ease of maintenance.



Integrated High-Voltage Pitch Control System

Hopewind Integrated High-Voltage Pitch Control System uses Hopewind independently developed dedicated pitch driver, which provides motor control, signal collection, grid monitoring, backup power charging monitoring, and other functions. They greatly simplify conventional pitch control system solutions, making the internal structure of the system simple with fewer failure points. The system also enhances reliability by manifold compared with conventional DC pitch control systems. The integrated pitch control system provides comprehensive fault protection, backup power health management, high/low voltage ride through, and startup heating and dehumidifying functions. It improves system reliability and availability while ensuring turbine safety.

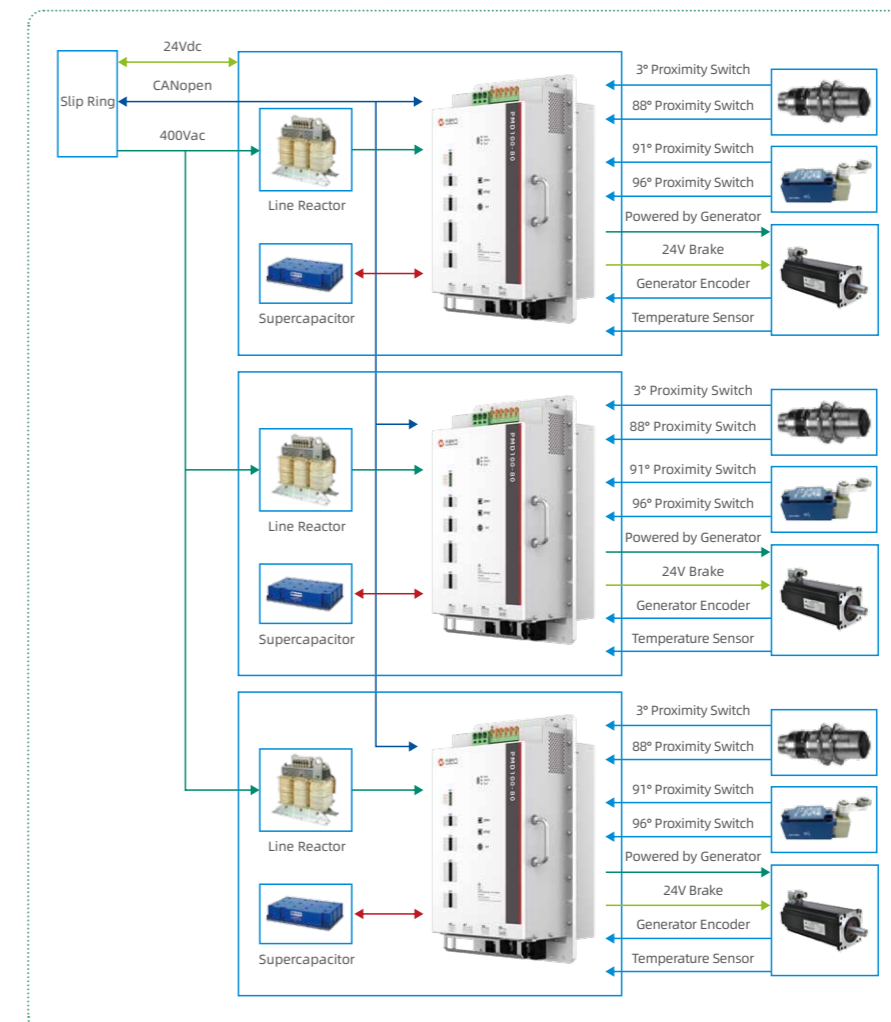

Pitch Control System

Product Characteristics

1 ■ High Integration

The PMD100-based Pitch Control System reduces 30% of components and cables, decreasing failure points and failure rates.

2 ■ Flexible and Easy to Use

The open and safe control platform, based on a built-in PLC and a wind power pitch application library, enables fast secondary development to meet diverse application requirements.

3 ■ Strong Environmental Adaptability

The system, with its broad operating temperature range (-40°C to +60°C), can function in extreme temperatures, high altitudes, and salt mist exposure. Additionally, its strong grid adaptability ensures compliance with low/high voltage ride through requirements.

4 ■ High Safety and Reliability

The hardware + software redundant safe feathering policy, together with the built-in hub speed detection and protection unit, guarantees the turbine unit's safety.

Technical Specifications

Type	Value	
Operating Environment	Operating Ambient Temperature	-30°C to +55°C (ambient temperature for the hub)
	Shutdown Storage Temperature	-40°C to +70°C
	Relative Humidity	≤95%
	Altitude	≤4000m, derating design required for altitude > 2000m
	Vibration Environment	5Hz~150Hz, with an acceleration of 10m/s ²
	Corrosion Resistance Class	C3 / C4
	Ingress Protection	IP54
Input AC Power Supply	Input Voltage	400VAC, 3L+N+PE
	Fluctuation Range	-20% to +35%
	Input Frequency Range	45Hz~66Hz
	Harmonic Content	<5%
Three-Axis Blade Angle Synchronization Deviation	≤1°	
Position Control Accuracy	Up to 0.01°	
0.01° Step Response Time	≤100ms	
Adapted Wind Turbine Power	1MW~20MW	

Integrated Pitch Driver



Hopewind PMD100 Integrated Pitch Driver offers comprehensive functionalities including generator control, CodeSys application programming, 24VDC power, backup power charging and discharging, high/low-voltage holding brake for the generator, and diverse IO signal interfaces. The driver can meet the pitch control requirements of WTGSs with maximum power of 20MW.



Performance Characteristics

● High Integration

The driver integrates the rectifier and inverter, 24VDC power module, supercapacitor charging/discharging, low-voltage holding brake, high-voltage holding brake, open programming platform, rich I/O interfaces, braking component, and other modules.

● Large-Capacity Auxiliary Power Output

The built-in large-capacity switch mode power supply provides rated 3A power output, which can meet the power supply requirements of pitch lubrication pumps.

● Strong Adaptability to Grid

The normal operating voltage range is 320VAC to 540VAC, and the operating frequency range is 45Hz to 66Hz. The driver can safely pitch under a surge impact of 170%Un and protect internal components against damage.

● Rich Backup Power Solutions

The driver is equipped with a built-in supercapacitor and a lithium battery management software module, which allow users to easily charge or discharge the backup power supply, and manage its status.

● High-Precision Detection of the Supercapacitor

High-precision current and voltage measurement and advanced energy algorithms are used to detect the capacity of the supercapacitor online.

● Parallel Connection of Dual Drivers

Two PMD100 drivers can be connected in parallel to drive a single generator or dual generators through fast buses inside the drivers, meeting the pitch drive requirements of 8MW~20MW WTGSs.

● Open and Safe Control Platform

The control platform using the ARM+DSP architecture provides users with sufficient flexibility for application control programming. The DSP program ensures safe pitching control in case of abnormal circumstances, guaranteeing the safety of WTGSs.

● Flexible Configuration Based on User Needs

Natural cooling components or air cooling heat dissipation components can be provided. CANopen/Ethernet communication interfaces can be provided. Built-in or external braking resistors can be selected.

Pitch Control System

Interface Type

Interface Type	PMD100-50	PMD100-80
Generator Encoder	1 (RDC / TTL)	1 (RDC)
Blade Encoder	1 (SSI)	
Bus Communication Interface	1 (CANopen)	
Safety DI	1	2
Safety Relay	1	2
D/DO/AI	20 / 10 / 3	20 / 12 / 3
PT100 Detection	4	
Generator Temperature Detection	1 (KTY / PTC / PT1000)	
Commissioning Interface	Ethernet	

Technical Specifications

Type	PMD100-50	PMD100-80
Rated Input Voltage	400Vac	
Input Voltage Range	320VAC~540VAC	
Rated Output Current	50AAC	80AAC
Peak Output Current	130Aac (3s)	280Aac (3s)
DC Bus Operating Voltage	150V~800V	
Charging Output Voltage	0V~500V	
Charging Output Current	0~5A	0~8A
Low-Voltage Holding Brake Output	24V / 4A	24V / 6A
High-Voltage Holding Brake Output	150-300V / 0.7A	
24V Power Output	3A	6A
Operating Temperature	-30°C to +60°C	-40°C to +60°C
Altitude	≤3000m	≤4000m
Ingress Protection	Inside Cabinet: IP20 / C3 Outside Cabinet: IP54 / C4	Inside Cabinet: IP20 / C3-H Outside Cabinet: IP54 / C5-M

Custom Permanent Magnet Synchronous Generator

- High precision, fast response, low heat generation, high reliability
- Compact size, light weight, easy maintenance and replacement



Lithium Battery Solution



Based on high-reliability lithium battery cells and BMS, Hopewind PBM125-2000 Lithium Battery Module has the following characteristics:

1 ■ Large Discharge Current

The permanent discharge current is -60A and the peak discharge current is -200A.

2 ■ Good Temperature Adaptability

It can run reliably in the range of -40°C to +60°C under heating conditions.

3 ■ Large Storage Capacity

10% partial discharge can meet the energy demand for single pitching.

4 ■ High Cost-Effectiveness

In high-power turbines, especially offshore WTGSs, it can properly substitute for supercapacitors.

Pitch Control System

Remote Monitoring of Pitch

The old SCADA system is incapable of sufficiently analyzing pitch faults. To retrofit and upgrade the pitch control systems for old models, Hopewind provides a solution for remotely monitoring the pitch system. This solution can manage and monitor the status of pitch systems of all the wind turbines in an all-round manner.

Product Characteristics

1 Independent Deployment

Collected pitch data is transmitted in wireless mode, eliminating the need to replace slip rings and demonstrating good applicability. Based on the original communication architecture of wind turbines, the pitch systems of all the wind turbines are monitored and managed in the centralized control room.

2 Failure Recording

The system boasts real-time fault alarm, history fault query, and fault waveform recording functions, and supports one-click export of fault data of one or more turbines.



Mobile Test Platform-Multi-functional Power Grid Simulator

Product Overview

Hopewind independently developed Multi-functional Grid Simulator can accurately simulate three-phase three-wire grid system with different voltages and frequencies and their dynamic disturbance characteristics. It is used for voltage deviation, frequency deviation, three-phase voltage imbalance, voltage flicker, grid harmonics, interharmonics, and other grid adaptability testing of equipment under test (EUT) such as wind power generation systems, photovoltaic power systems, and energy storage systems. The product can also accurately simulate various grid fault characteristics, including high voltage and low voltage, symmetrical and asymmetrical fault states, to conduct the high voltage ride through test and low voltage ride through test on EUTs such as wind power generation systems, photovoltaic power systems, and energy storage systems.

Functional Diversification

1 Grid Adaptability Test

- Voltage
- Frequency
- Three-phase voltage imbalance
- Flicker
- Harmonic voltage
- Interharmonics

2 Grid Fault Voltage Ride Through Test

- High voltage
- Low voltage
- Cascading failure

3 Grid Support Test

- Primary frequency control
- Inertia response
- Impedance characteristic test
- Weak grid connection test

Product Types

1 2.5MVA



2 6MVA



3 10MVA



Note: The external silkscreen on the container can be customized by customers. The picture is for reference only.

Mobile Test Platform-Multi-functional Power Grid Simulator

Performance Characteristics

- The product capacity ranges from 1MVA to 60MVA. Different voltage levels and test functions can be customized.
- The isolated anti-impact capability enables the product particularly suitable for tests in weak grid environments.
- The product supports grid impedance simulation and frequency scanning test functions.
- The harmonic output accuracy is up to $\pm 0.2\%$.
- The quality of output voltage waveforms is good and the Rated No-load Output THDu is $\leq 0.5\%$.
- The product supports parallel connection of multiple units for expansion.

Technical Specifications

Parameters	Power	2.5MVA	6.0MVA	10.0MVA
Product Types		Coupled	Cascade	
Input Voltage		AC35kV $\pm 10\%$ / AC10kV $\pm 10\%$ / AC6kV $\pm 10\%$		
Input Frequency		50Hz $\pm 5\%$		
Steady-state Output Voltage Range		80% to 110%		
Steady-state Voltage Accuracy		0.5%		
High Voltage Output Range		110% to 130%		
Low Voltage Output Range		0% to 90%		
Output Frequency Range		45Hz~66Hz		
Output Frequency Accuracy		0.01Hz		
Output Waveform Distortion Rate		$\leq 1\%$		
Three-phase Voltage Imbalance Output Range		1% to 10%		
Three-phase Voltage Imbalance Output Accuracy		0.1%		
Output Flicker Pst		1~10		
Output Flicker Accuracy		0.1		
Output Harmonics		2~50 times		
Output Harmonics Accuracy		0.2%		
System Efficiency		$\geq 95\%$		
Noise		$\leq 70\text{dB}$	$\leq 85\text{dB}$	
Storage Temperature		-40°C to +70°C	-30°C to +55°C	
Operating Temperature		-30°C to +40°C	-25°C to +40°C	
Altitude		$\leq 3500\text{m}$		
Cooling Mode		Liquid Cooling	Air Cooling	
Ingress Protection		IP54	IP23	

Note: Some function parameters can be customized based on customer needs.

Industry Applications

1 Example of the WTGS Test

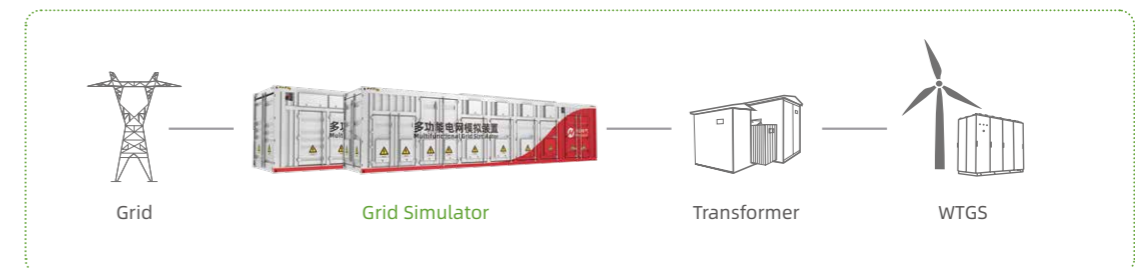

2 Example of the Photovoltaic Power Generation Unit Testing

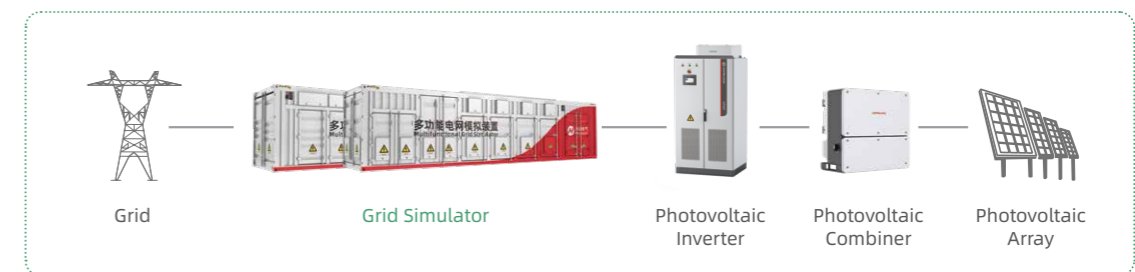

3 Example of the Energy Storage System Test

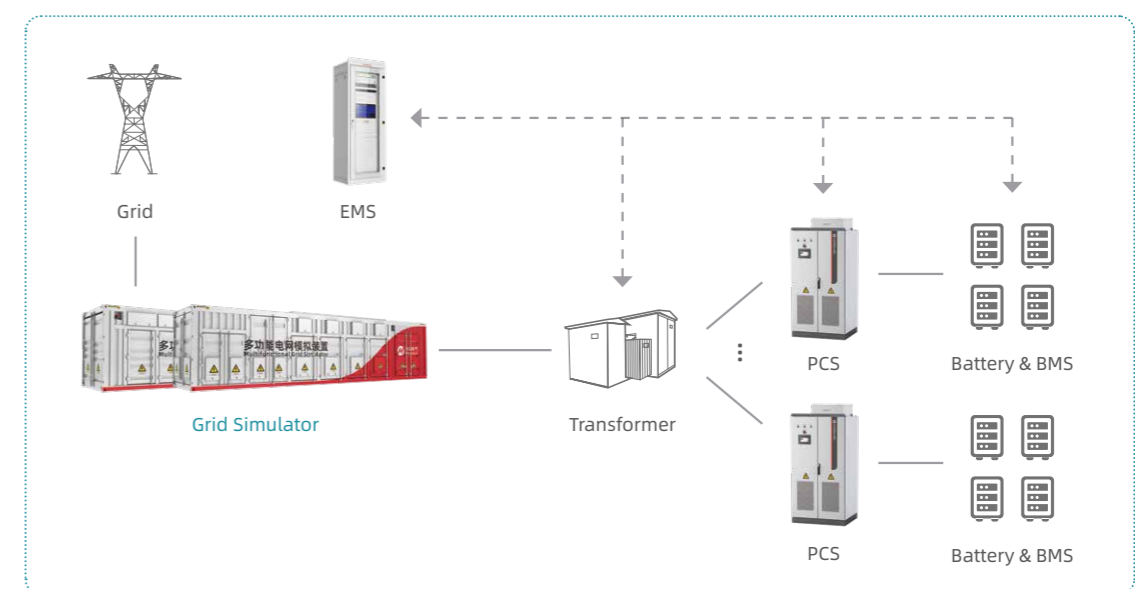

hopeView Network Monitoring System

The system monitors the network of wind power converters by utilizing the optical fiber ring network and servers in the wind farm. While ensuring power operation safety, the system conducts precise monitoring and intelligent diagnosis of WTGSs based on a large amount of high-resolution real-time data collected by the converters. This maximizes the O&M level of the wind farm, minimizes downtime of WTGSs, reduces power generation losses, and ultimately increases power generation benefits of the wind farm.

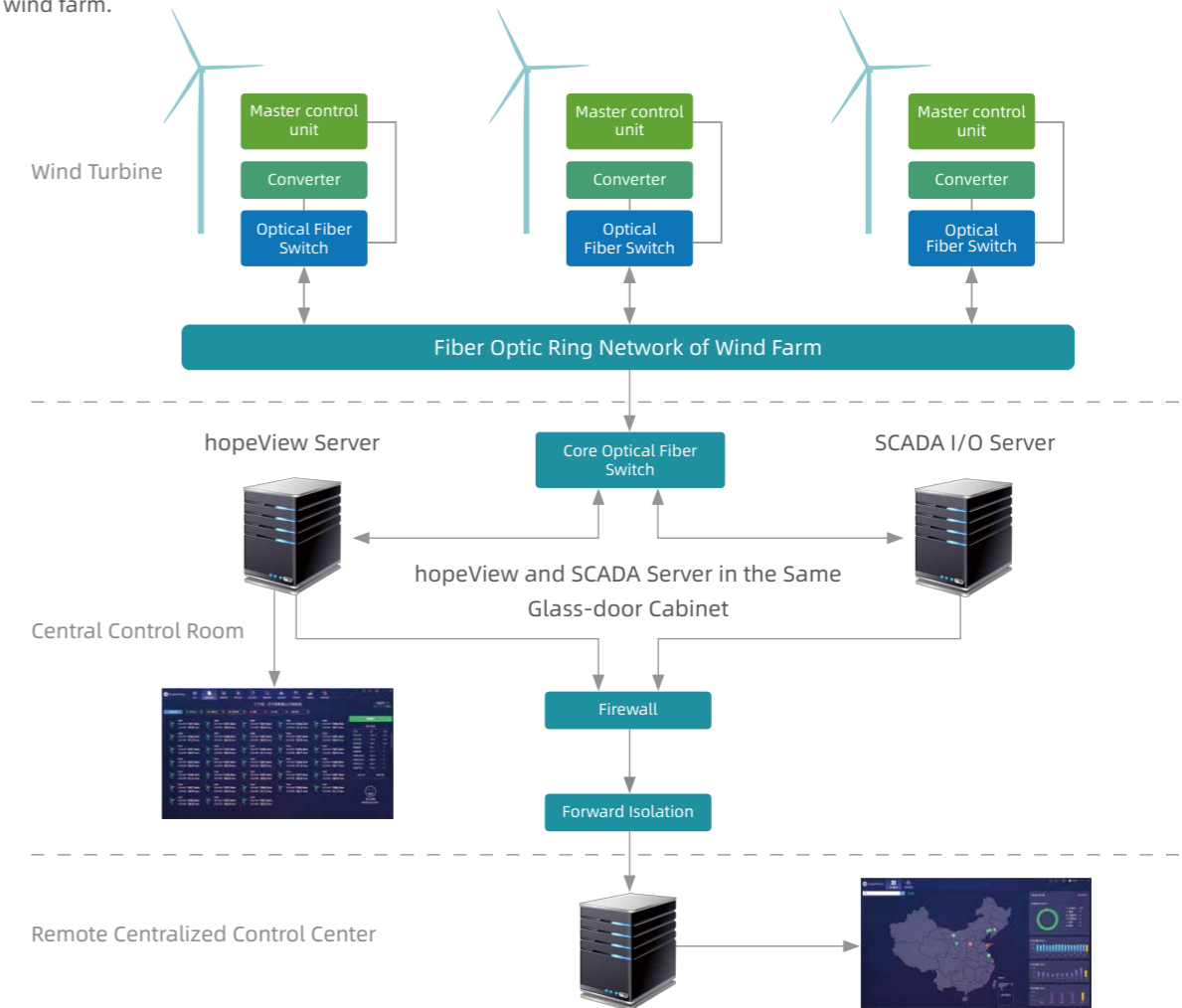

Remote O&M Products

hopeView Network Monitoring System

Special Functions

Performance Characteristics

- Wind farm-level operating status monitoring, operation trend analysis
- Wind turbine-level real-time data monitoring, full coverage of important parameters, in-depth data analysis
- Remote assistance in monitoring turbine power quality
- Early warning for drive chain failures, helping the turbine diagnose faults
- Remote oscilloscope function available for electrical faults, to obtain in-depth data
- Fast identification of power grid failures, to provide timely protection
- Multi-dimensional customized reports, easy-to-understand rich wind farm statistics
- Multi-directional and multi-level monitoring and comparison, to help identify areas to be optimized

Benefits

- Converter faults can be handled by accessing the wind turbine only once according to the fault diagnosis and handling suggestions.
- Maintenance and prevention can be provided in advance based on trend prediction to prevent faults from spreading.
- Targeted maintenance can be conducted based on fault statistics to improve maintenance efficiency.
- It helps train professional maintenance teams and reduces the dependency on converter manufacturers.

Special Functions

01 Operation Data Monitoring

High-Precision Multi-Variable Data Acquisition

Compared with the SCADA system, hopeView's data collection function has the following characteristics:

A Large Amount of Data Collected

- Real-time electrical parameters (over 100) of all wind turbines can be displayed.
- Real-time electrical parameters (over 2000) of a single wind turbine can be displayed in detail.
- As many as 10 million event records and more than 100,000 fault waveform records can be stored.

High Resolution for Key Data

- The resolution of data before and after faults can reach 3kHz.
- For specified data, real-time collection and waveform drawing and recording can be done at a resolution of 1.5kHz.
- For data that requires long-term tracking, historical trends can be plotted at a resolution of seconds.

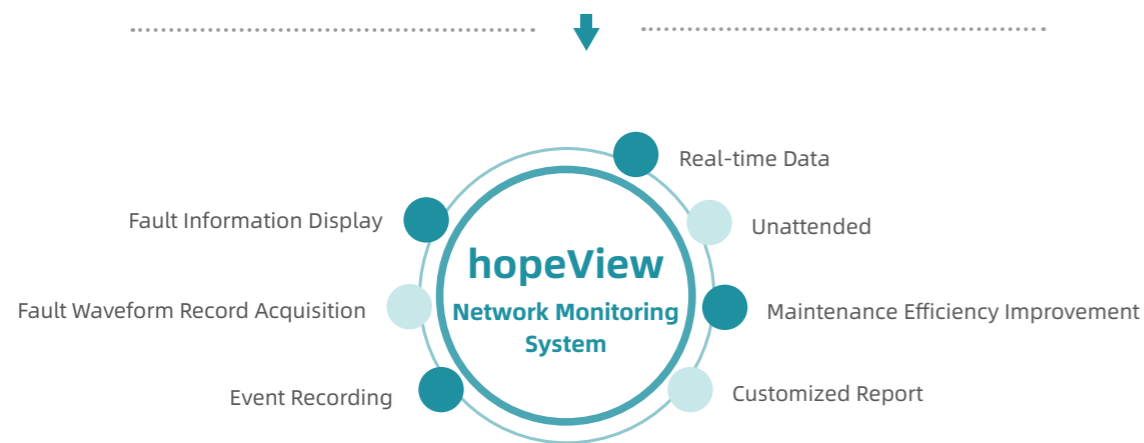
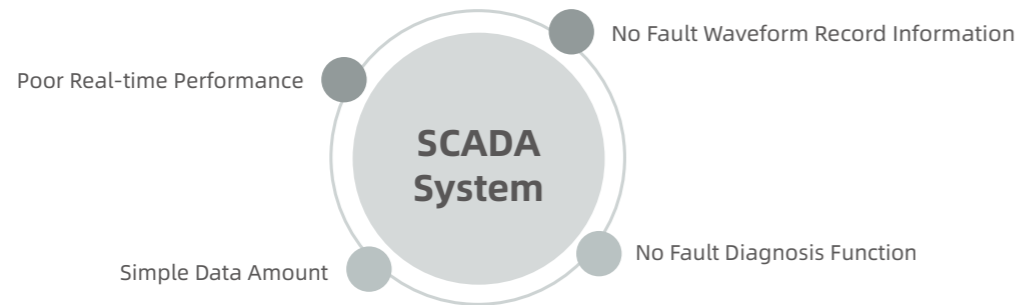

02 Intelligent Fault Diagnosis

In-Depth Data Analysis

Hopewind, based on deep computing and years of maintenance experience, has proposed two intelligent fault diagnosis methods for WTGSs:

1 ■ Fault Diagnosis Guide

The expert system provides a technical expert analysis case summary, that is, case analysis library.



2 ■ Intelligent Fault Diagnosis and Prediction

Automated fault analysis, no manual intervention required

- **Fault diagnosis:** Professional analysis is conducted on fault waveform records, event records, and other information to rapidly and accurately pinpoint fault causes.
- **Trend prediction:** The system monitors trends of specific parameters to figure out whether hidden risks exist based on specific algorithms so that preventive measures can be taken in a timely manner.

Intelligent Fault Diagnosis Scope

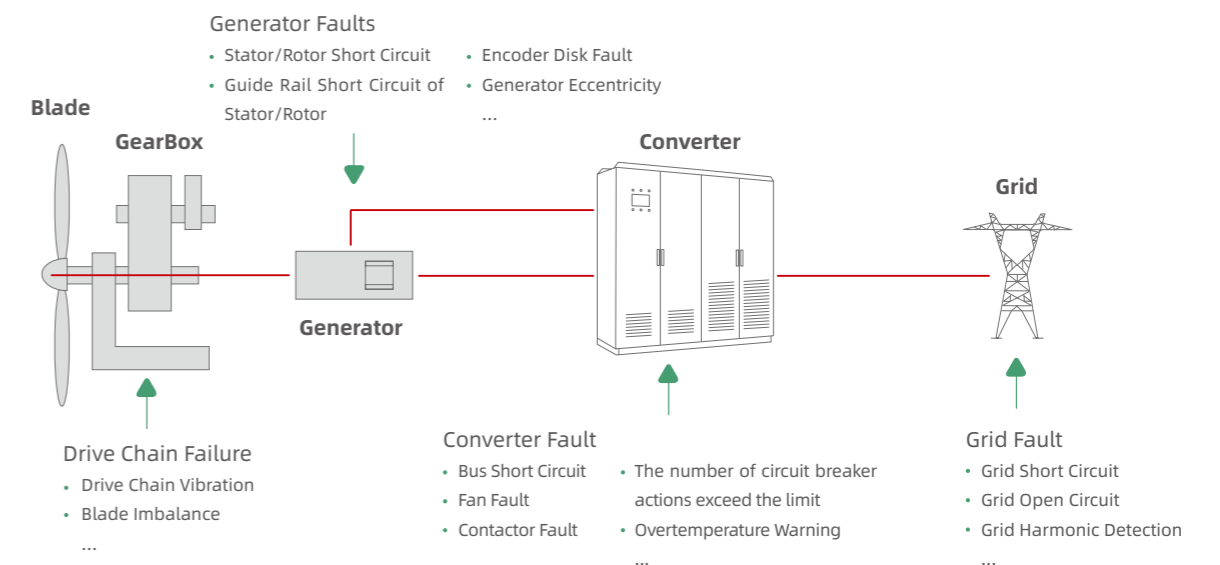

Special Functions

Intelligent Diagnosis and Display

In-Depth Data Analysis

Production Management Function

Featured Data Statistics

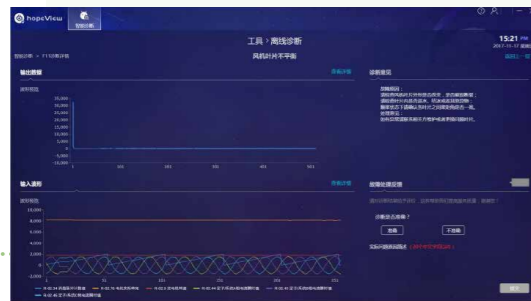

1 Intelligent Blade Imbalance Diagnosis



2 Intelligent Diagnosis of Generator-Side Short Circuit

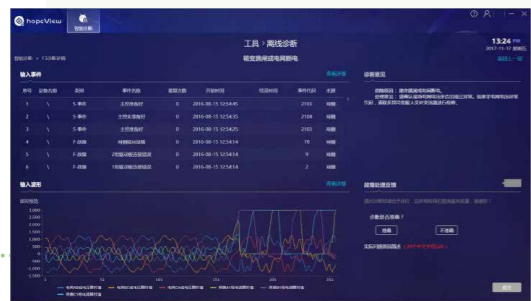

3 Intelligent Diagnosis of Grid Outage



4 Intelligent Diagnosis of Encoder Disk Signal Loss

By monitoring and comparing power curves and power generation in multiple aspects, hopeView Network Monitoring System can learn about the operation of the wind farm and equipment in real time, assist in identifying areas to be optimized, help improve power generation, and raise the overall operation level of the wind farm.



The system supports the fault statistics function. It can collect statistics on faults on a semi-monthly, monthly, quarterly, semi-yearly, and yearly basis, generate fault statistics reports, and rank the faults. It collects statistics on frequent faults of the wind farm or wind turbines in a certain period of time, and conducts specific optimization for these frequent faults to improve the operation effect of the wind turbines.

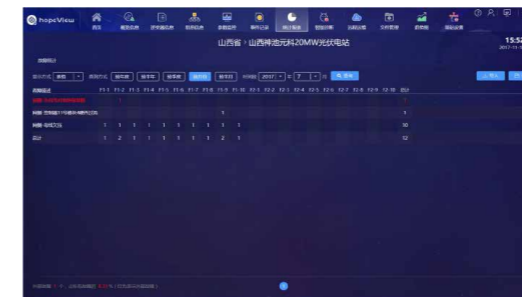

Converter faults that rank top in the wind farm in a certain period of time are displayed.

Wind turbines that rank top in the wind farm in a certain period of time are displayed.



Typical Cases



Batch Application of Offshore Wind Power Converters

- Time: 2016 to present
- Locations: Jiangsu (Rudong, Binhai, Hai'an, Dafeng, Qidong), Guangdong (Zhanjiang, Yangjiang, Jieyang, Zhuhai), Fujian (Xinghua Bay, Fuqing, Pingtan, Changle), Zhejiang (Daishan, Jiaxing, Shengsi, Yuhuan, Cangnan, Xiangshan), Shanghai (Lingang), Liaoning (Zhuanghe), Shandong (Dongying)
- Introduction: Over 1,000 sets of Hopewind offshore converters have been installed successively and are operating stably to date in highly humid, saline, and misty environments with frequent thunderstorms.



Batch Operation of Wind Power Converters Outside China

- Time: 2012 to present
- Locations: Lubbock Wind Farm, Texas, USA; Progreso Wind Farm, Yucatan Peninsula, Mexico; Ulyanovsk Wind Farm, Russia; Activity Wind Farm, Russia; Aysha II Wind Farm, Ethiopia; PEPL Project, India; Ninh Thuan Zhengsheng Wind Farm, Vietnam
- Introduction: Hopewind actively participates in global wind power construction, and has installed over 200 sets of high-power wind power converters in multiple countries across the Americas, Europe, Africa, and Asia since 2012. These converters operate reliably and stably, earning high praise from global owners.



Batch Operation of Converters in Plateau/Ultra-Plateau Environment

- Time: 2009 to present
- Locations: Cuomeizhegu Ultra-high-altitude Wind Farm in Tibet; Xuebangshan Wind Farm in Dali, Yunnan; Shazhuyu Wind Farm in Gonghe, Qinghai, and Xueshan Highland Wind Farm in Huidong, Sichuan
- Introduction: In Cuomeizhegu Wind Farm in Tibet (at an altitude of 5,000 meters), Xuebangshan Wind Farm in Dali, Yunnan (at an altitude of 3,800 meters), Shazhuyu Wind Farm in Gonghe, Qinghai (at an altitude of 3,500 meters), and Xueshan Wind Farm in Huidong, Sichuan (at an altitude of 3,300 meters), over 1,000 sets of Hopewind plateau-type (3,000-4,000 meters)/ultra-plateau-type (above 4,000 meters) converters have been installed successively. They all have been successfully connected to the grid for power generation and have been running stably to date.



Distributed Wind Power Generation Solution

- Time: 2013
- Location: Summer Camp, Hologol, Inner Mongolia
- Introduction: The Hologol Summer Camp Wind Farm of State Power Investment Corporation is located in Summer Camp, Hologol, Inner Mongolia. It is a typical demonstration project for distributed wind power on-site consumption. The average altitude at the site is 1,100 meters, with long and cold winters as well as ice and snow accumulation. WTGSs operate in harsh conditions at a temperature as low as -25°C throughout the year. The wind farm has a gross installed capacity of 300MW and all the generators use Hopewind 2.0MW plain-type distributed low-temperature doubly-fed converters.



Sub-Synchronous Resonance Solution

- Time: 2016
- Location: Xinhua Wind Farm, Tongyu County, Jilin Province
- Introduction: A sub-synchronous resonance event occurred in the Zhangjiakou power grid in 2014, causing almost all the wind turbines in the area disconnected from the grid. Hopewind developed the "enhanced grid adaptability function" to successfully solve the problem. In 2016, sub-synchronous resonance also occurred at Xinhua Wind Farm in Tongyu, Jilin Province. Only the wind turbines equipped with Hopewind converters remained connected to the grid and continued operation after the sub-synchronous resonance occurred.



World's First Electric Train Ride-Through Solution

- Time: 2009
- Location: Sanmenxia Wind Farm in Henan Province
- Introduction: The customer has long been bothered by frequent tripping and disconnection of wind turbines due to a severe imbalance in the grid caused by electric trains passing through. Hopewind converters are applied in the wind farm for the first time and perfectly resolve the trouble.

150 GW⁺

SHIPMENTS WORLDWIDE



Email: marketing@hopewind.com

Tel: +86 189 4874 2347

Website: www.hopewind.com

©2024 Hopewind Electric Co., Ltd. All rights reserved. V4.4.2

If the product size and parameters have changed, the latest actual product shall prevail